

**Push Button Minute Timer for LED lighting with built in multi-way control
Programmable between 1 minute and 30 minutes**

PRODUCT SUMMARY AND CAPABILITIES

Designed in Australia to provide optimised switching of LED based lamps and drivers, this high quality, two-wire electronic timer switch mechanism can be connected in parallel to other LEDsmart+ devices to provide a simple solution to multi-way control.

As part of the LEDsmart+ range, this electronic timer switch enables all LEDsmart+ dimmers, switches and timers to be combined onto the same wall plate, providing the user with a consistent look and feel.

PRODUCT FEATURES

- Programmable between 1 minute and 30 minutes in 1 minute steps
- Mix switching, dimming and timing on the same circuit
- Suitable for one-way, two-way, three-way and multi-way control
- MultiMate™ technology allows multi-way control with no extra wires
- Suitable for both retrofit and new installations
- Active only 'two wire' connection - no neutral required
- Override feature to stop the lights turning off automatically
- Advanced warning feature to dim the lighting to 50% level for 5 minutes before switching off
- Mode to convert from Minutes Timer to Hours Timer
- Programmable maximum level and off state indicator
- Simple 3-step timer interval setting
- Flush and rocker style button options
- White illuminated halo with interchangeable coloured rings (blue / green / orange / clear)
- Quiet, soft press button - no harsh click
- 1W minimum load



Powered by
MultiMate
TECHNOLOGY
Patented
Registered Design



Designed in Australia to
meet Australian
Standards and
installation conditions



PROGRAMMABLE SETUP FUNCTIONS

Timeout period	The timer allows a duration of 1 to 30 minutes in increments of 1 minute. Default: Timeout period is set to 15 minutes.
Maximum Brightness	The maximum brightness level provided by the timer can be set to suit customer requirements. Default: The maximum brightness is set to the highest output.
Advanced Timer	The advanced timer mode provides an optional advanced warning to the user that the lights will shortly turn off automatically When the advance timer is enabled, at timeout the lights are dimmed to 50% over a 4 second period and are held at this 50% level for 5 minutes. After this 5 minutes, the lights are turned off automatically Default: Advanced Timer Mode is disabled.
LED indicators	The timer switch's white LED indicators can be set to glow on or turn off when the switch is off Default: The white LED indicators are set to glow on when the timer is turned off.
Converting from minute to hour timer	If required, this minute timer can be converted to an hour timer, with a timeout settable between ¼ hour and 7½ hours, in ¼ hour increments.
MultiMate™ ON/OFF	MultiMate™ functions can be switched ON or OFF Default: MultiMate™ features are switched on.

A wide range of LED and CFL lamps are available from different manufacturers. The following issues are occasionally seen when used in conjunction with 2-wire dimmer/timer/switch products:



- When switched off, the LED/CFL lights flicker, pulse on/off or do not switch off completely.
 - When switched off, the LEDsmart+ LED indicators flicker.
 - When switching on, the LED/CFL lights have difficulty switch on and the dimmer indicators flicker or pulse.
- If these are experienced: Install a LEDsmart+ Load bypass device (item code **MMBP**) across the lamp Line and Neutral terminals to provide improved system performance.

MULTIMATE™ TECHNOLOGY

MultiMate™ is a technology inside the range of high quality LEDsmart+ dimmers, sensors, timers and electronic light switches. It allows multi-way control of lighting without the need for an expensive control system. MultiMate™ technology is suitable for both new and retrofit installations.

MultiMate™ technology enables multiple LEDsmart+ two-wire devices to be wired in parallel when two-way, three-way or multi-way dimming and switching is required.

When connected in parallel, LEDsmart+ dimmers, switches, timers and occupancy sensors allow dimming (and switching) of connected lighting loads from multiple locations without any additional wiring. No strapper wires, dedicated remote switch wiring or control bus is required.

MultiMate™ is a patented technology, developed in Australia by Pierlite and Ozuno.

The wiring example shows two LEDsmart+ dimmers connected in parallel with a LEDsmart+ Occupancy Sensor. Together these provide user-controlled two-way dimming with Occupancy Sensor ON or OFF functions on four downlights without any additional wiring.

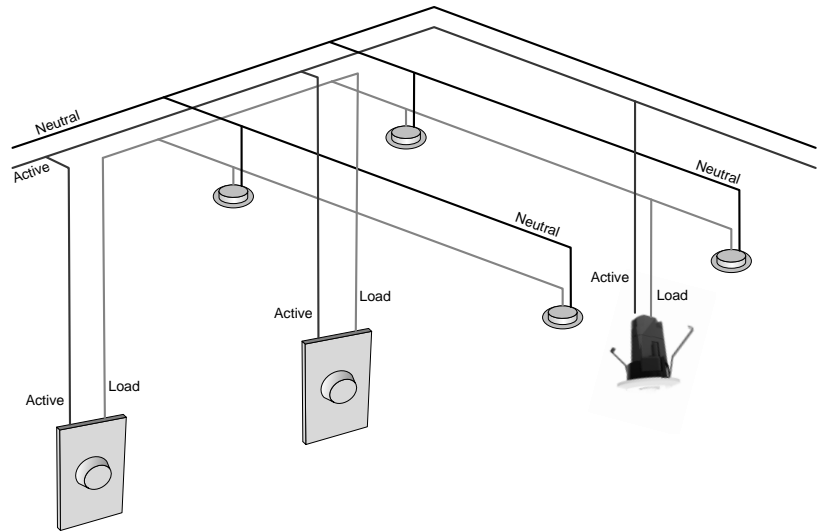

PRODUCTS WITH MULTIMATE™ TECHNOLOGY INCLUDED

MultiMate™ technology is included in the following products. They can all be connected in parallel to allow multi-way control. *Note that different types of MultiMate™ products can be connected in parallel.*

For example: dimmers, motion sensors, switches and timers can be connected in parallel to control the same group of lights from different locations and/or provide additional functionality.

Item Code	Description	Features
MMDM/RT	LEDsmart+ Rotary Dimmer / Switch	Rotary Dimmer with built in on/off switch and multi-way control
MMDM/PB	LEDsmart+ Push Button Dimmer	Push Button Dimmer with built in on/off switch and multi-way control
MMSE/PR	LEDsmart+ 360° Occupancy Sensor	360° Occupancy Sensor programmable between 1 minute and 60 minutes with multi-way control
MMTM/PB	LEDsmart+ Push Button Minute Timer	Push Button Timer programmable between 1 minute and 30 minutes with multi-way control
MMTH/PB	LEDsmart+ Push Button Hour Timer	Push Button Timer programmable between ¼ hour and 7 ½ hours with multi-way control
MMSW/PB	LEDsmart+ Push Button Electronic Switch	Push Button Electronic Switch for LED lighting with built in on/off switch and multi-way control
MMDM/DD	LEDsmart+ Digital Level Display	Level Display for use with any dimmer
MMSR	LEDsmart+ Slave Relay	10A Relay for On/Off control from trailing edge dimming devices

ROCKER AND FLAT PUSH BUTTONS

Two different styles of push buttons are included.

Either can be used depending on customer preferences.

The Rocker Button is pre-fitted to the timer.



COLOURED BEZELS

The timer has white LED indicators and the pre-fitted bezel provides a white glow around the button. Interchangeable blue, green and orange bezel rings are also included with the timer. These can be used to change the colour of the LED indicators to match customer colour preferences and/or to more easily identify different LEDsmart+ devices on the same grid plate.

INSTALLING LEDSMART+ DEVICES INTO CLIPSAL SATURN™ OR CLIPSAL SATURN ZEN™ WALL PLATES

Adaptor kits are available separately to enable LEDsmart+ devices to be installed into Clipsal Saturn™ or Clipsal Saturn Zen™ wall plates. Order codes are as follows.

DGACCESSPK2	Adaptor kit for LEDsmart+ Push Button devices
DGACCESSPK3	Adaptor kit for LEDsmart+ Rotary dimmers

WIRING DIAGRAMS

ONE-WAY TIMER

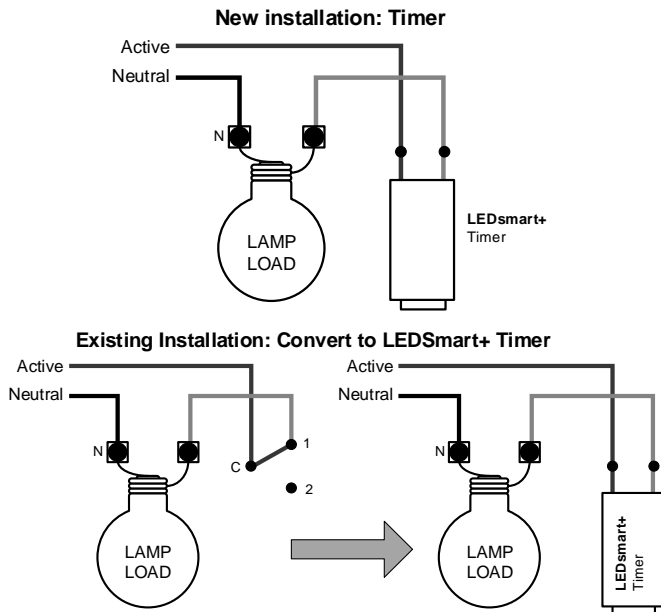

TWO-WAY SWITCHING / TIMING / DIMMING

For two-way control using LEDsmart+ products, they are connected in parallel.

Any LEDsmart+ products can be connected in parallel. For example an LEDsmart+ push button timer and dimmer can be wired in parallel to provide two-way control.

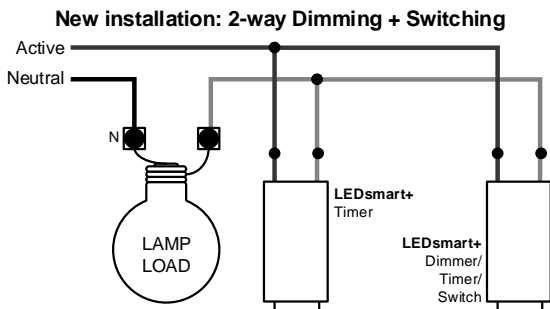

Two-way control using an LEDsmart+ timer and an additional LEDsmart+ switch, dimmer or timer. Note these devices are simply wired in parallel.

When replacing existing two-way switching with two-way control using LEDsmart+, the existing two-way strapper wires can be re-used. No new wiring is required.

Existing installation: 2-way switching to switching + dimming

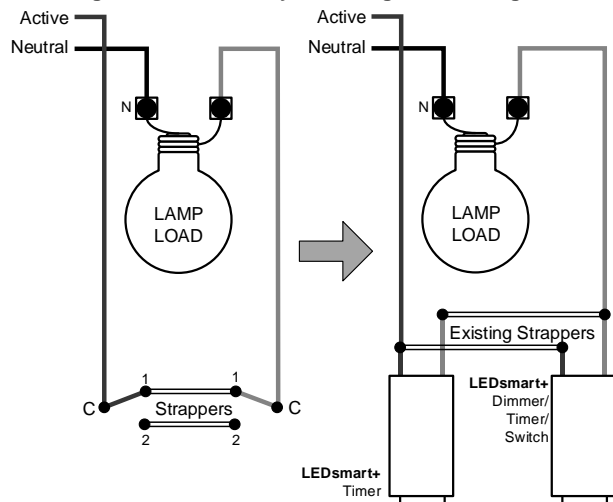

MULTI-WAY (THREE-WAY OR MORE) DIMMING AND SWITCHING

For multi-way dimming, timing and switching using LEDsmart+ dimmers, all switches, dimmers, timers and sensors are connected in parallel.

The diagrams show the wiring for three-way switching, timing and dimming using LEDsmart+ switches, timers and dimmers. If more than three-way control is required, further LEDsmart+ devices are simply wired in parallel.

New installation: 3-way or more way Dimming + Switching

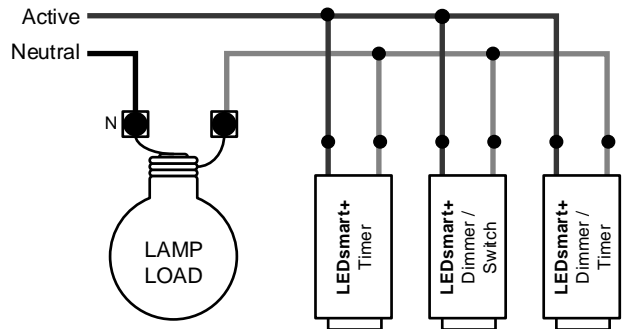

When replacing existing three or more way switching with multi-way dimming/timing/switching using LEDsmart+, the existing strapper wires can be re-used. No new wiring is required.

Existing installation: 3-way switching to switching + dimming

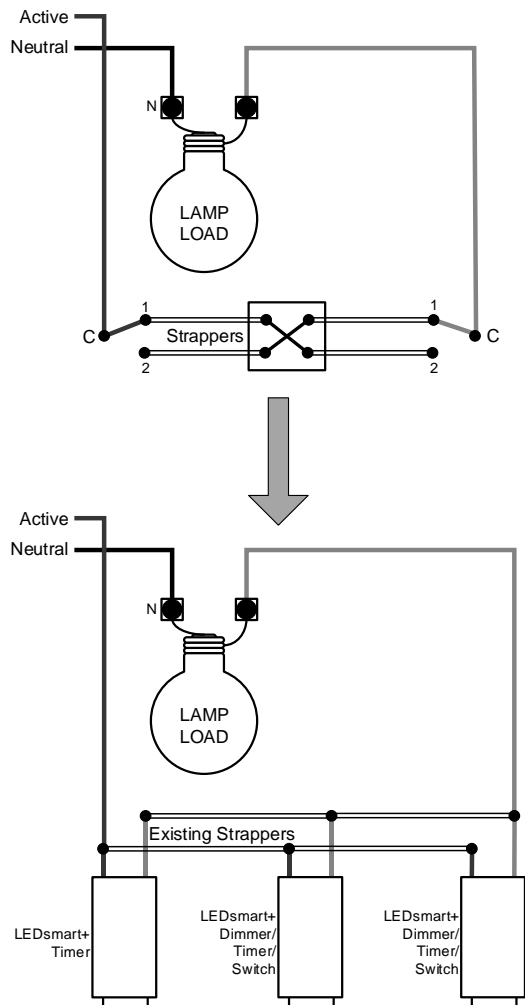

SPECIFICATIONS







Nominal Line Voltage	220-240Vac
Line Frequency	50Hz Nominal (47 – 53Hz)
Load Brightness Control Range	0% to 100% (typical for LED loads)**
Rated Load	Refer Compatible Loads table (below)
Minimum Load	1W
Maximum cable distance between LEDsmart+ devices	50m (for example, two LEDsmart+ devices can be separated by up to 100m provided that the maximum distance from the furthest device to the parallel junction point is no more than 50m).

** Refer note on first page. An MMBP may be needed to prevent off-state LED glow in some cases.

COMPATIBLE LOAD TYPES

The LEDsmart+ range are compatible with lighting loads that are designed for use with Phase Angle / Phase Cut dimmers.

Lighting loads that have not been designed for use with non-separately switched dimmers typically require the use of the MMBP Load Bypass device to achieve compatibility.

Load Symbol	Load Types	Max Load	Notes
	Dimmable LED Lamps	400W	The LED driver must be dimmable. Maximum permitted number of drivers is 400W divided by the driver nameplate power rating. Due to variety of LED lamp designs, maximum number of LED lamps is also dependent on power-factor result when connected to the timer.
	Electronic Transformers	400W	
	Standard iron-core transformers	250W	Due to variety of transformer designs, max LV lighting load is also dependent on transformer efficiency.
	Toroidal iron-core transformers	300W	
	Incandescent	350W	
	Dimmable CFLs	400W	Due to the variety of CFL designs, the maximum number is make/model dependent.

INCOMPATIBLE LOAD TYPES

The timer is designed to **switch lighting loads only**. It is not suitable for switching ceiling sweep fans, exhaust fans or other non-lighting devices which require an air-gap type switch. If control of a non-lighting load is required, consider using the MMSR Slave Relay accessory.

MULTI-GANG DE-RATING

In applications where multiple timers, switches or dimmers are installed in a multi-gang plate, a de-rating factor is applied to the maximum load as follows.

Number of times per plate	De-rating factor
1	No de-rating
2	0.85
3	0.7
4	0.55
5	0.4
6	0.25

De-rating Example

Two LEDsmart+ devices installed in a wall plate. The maximum LED load which can be connected to each device = $400W \times 0.85 = 340W$ per device.

TIMER INSTALLATION



This product must be installed by a suitably qualified installer who must work in accordance with standard safety procedures for mains-powered electrical equipment.

The terminal block included with the timer should be used to carry out the electrical connections, as shown below.

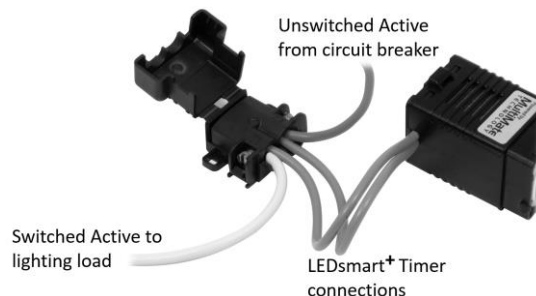

Once the connections have been made, the terminal cover is closed to ensure the screw terminals are not exposed.

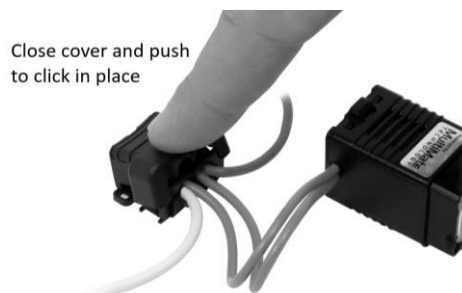

The terminal block can then be cable-tied to the rear of the timer utilising the two loop holes.

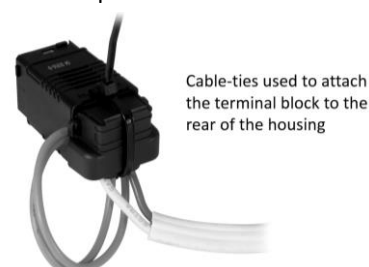

TIMER SETUP

The LEDsmart+ push button timer has a number of functions that can be set by entering setup mode and following three easy steps.

TIMEOUT PERIOD should always be set. The other settings are optional, depending on the application.

SETTINGS ARE SHARED

When multiple LEDsmart+ timers are used on the same controlled circuit, some setup properties are communicated and shared between them. For specialised applications this can be disabled.

TIMER SETUP FUNCTIONS

Function	See Part
Entering Setup Mode	A
Setting Timeout Period	B
Setting Maximum Brightness	C
Setting Advanced Timer Option	D
Setting Off State LED Feature	E
Converting from minute to hour timer	F
Setting MultiMate™ Mode	G
Factory Defaults Reset	H



Once in Setup mode, options are selected by a series of clicks of the timer push button.

Each click should be approximately 1 second after the previous click.

A: ENTERING SETUP MODE

If the timer has been powered up for **LESS THAN 15 MINUTES** see **A1**.

If the timer has been powered up for **MORE THAN 15 MINUTES** see **A2**.

A1: TIMER HAS BEEN POWERED FROM MAINS FOR LESS THAN 15 MINUTES

1. Press and hold the button for **10 seconds**.

Connected lights will switch or dim, this is normal.



2. The white LED Indicators will blink ON/OFF twice per second. This indicates that the timer is now in Setup Mode.

If more than one LEDsmart+ device is connected in parallel, they all enter setup mode. The blink ON/OFF will also be seen on all other LEDsmart+ devices connected in parallel.

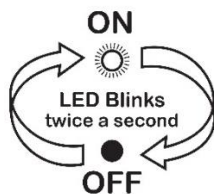

In the unlikely event that other LEDsmart+ devices connected in parallel do not enter setup, exit and try again.

3. The timer is ready for the settings to be adjusted as required. Go to the relevant setup function instructions.



A2: TIMER HAS BEEN POWERED FROM MAINS FOR MORE THAN 15 MINUTES

1. Press and hold the button for **30 seconds**.

This resets the Setup Entry time back to 10 seconds (for the next 15 minutes) Connected lights will switch or dim, this is normal.

Press & Hold!



2. The white LED Indicators will blink ON/OFF twice per second. This indicates that the timer is now in Setup Mode.

If more than one LEDsmart+ device is connected in parallel, they all enter setup mode. The blink ON/OFF will also be seen on all other LEDsmart+ devices connected in parallel.

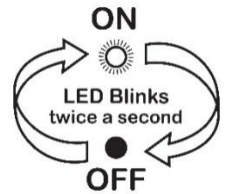

In the unlikely event that other LEDsmart+ devices connected in parallel do not enter setup, exit and try again.

3. The timer is ready for the settings to be adjusted as required. Go to the relevant setup function instructions.



B: SETTING TIMEOUT INTERVAL

Minutes timer allows a timeout duration of between 1 to 30 minutes in increments of 1 minute. Out of the box (factory defaults), the time out interval is set to 15 minutes.

To change the time out interval from the default 15 minutes, follow the steps below.

1. Enter the timer **Setup Mode** - See **PART A**.

Setup Mode!



2. Click the push button **2 times**.



3. The LED will blink 2 times.

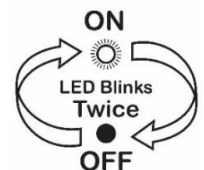

4. Press and hold the button to set the timeout. Count the blinks. Each blink adds 1 minute.

Setting a timeout of 0 will set 1 minute.

Adjust!



5. When the number of blinks is the number of minutes required, release the button.

The timeout interval will be saved and setup will exit automatically.

The timeout period on LEDsmart+ timers connected in parallel must be set individually. The same timeout is not automatically set across units.

Release!



C: SETTING MAXIMUM BRIGHTNESS

The maximum brightness level provided by the timer can be set to suit customer requirements.

When lamps are near to full brightness, it is difficult to see changes in dimming level. Therefore, when setting maximum brightness, it is recommended that the lamp is slowly dimmed up to a point where no further changes in brightness can be seen, and the maximum level set at this point.

1. Enter the timer **Setup Mode** - See **PART A**.

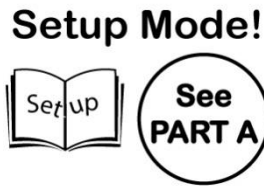

2. Click the push button **3 times**.



3. The LED will blink 3 times.
If more than one timer is connected to the same load, they will all now blink 3 times.

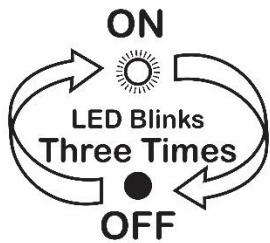

4. Press and hold the button to adjust to required maximum brightness level.

The direction of adjustment will alternate with each press-and-hold.

To cancel/exit do nothing for 30 seconds

5. Click once to save & exit.

If there are multiple LEDsmart+ timers connected in parallel, the maximum brightness levels only needs to be set in one device. The setting is automatically saved to all other LEDsmart+ timers connected in parallel.



D: SETTING ADVANCED TIMER OPTION

The timer includes an optional advanced timer warning to the user that the lights will soon turn off automatically.

When this option is enabled - at timeout the lights are dimmed to 50% over a 4 second period and are held at this 50% level for 5 minutes. After this 5 minutes, the lights are turned off automatically

To enable the advanced timer option, follow the steps below.

1. Enter the timer **Setup Mode** - See **PART A**.



2. Click the push button **4 times**.



3. The LED will blink 4 times.
If more than one timer is connected to the same load, they will all now blink 4 times.

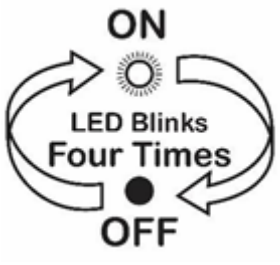

4. To enable the advanced timer option - press and hold the button until the lamp(s) turn ON.

To disable the advanced timer option – press and hold the button until the lamp(s) turn OFF.

To cancel/exit do nothing for 30 seconds.

5. Click once to save & exit.

Advanced Timer mode for LEDsmart+ timers connected in parallel must be set individually. A change of mode is not automatically set across units.



DURING THE ADVANCED TIMER 5-MINUTE WARNING PERIOD:

- The LED indicators will blink at a faster rate;
- A tap on the push button will restore the load to 100% ON and the timer will restart;
- A long press of the push button will turn the load OFF.

E: SETTING OFF STATE INDICATION

When the timer is off, the white LED indicators in the timer can be set to glow or turn off. By Default, the white LED indicators are set to glow when the timer is turned off.

To set the LED indicators to turn off when the timer is off, follow the steps below.

1. Enter the timer **Setup Mode** - See **PART A**.

Setup Mode!



2. Click the push button **5 times**.



3. The LED will blink 5 times.

If more than one timer is connected to the same load, they will all now blink 5 times.

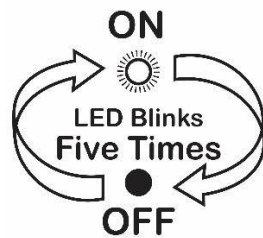

4. To enable indicator glow when the timer is OFF: press and hold the button until the lamp(s) turn ON.

To disable indicator glow when the timer is OFF: press and hold the button until the lamp(s) turn OFF.

To cancel/exit do nothing for 30 seconds.

5. Click once to save & exit.

Indicator off-state setting for LEDsmart+ timers connected in parallel must be set individually. A change of mode is not automatically set across units.



F: CONVERT MINUTE TO HOUR TIMER

If required, this minute timer can be converted to a standard LEDsmart+ hour timer, with a time out adjustable between ¼ hour and 7½ hours, in ¼ hour increments.

To convert to an hour timer, follow the steps below.

1. Enter the timer **Setup Mode** - See **PART A**

Setup Mode!



2. Click the push button **6 times**.



3. The LED will blink 6 times.

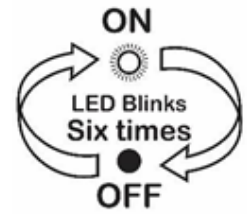

4. To change the operation to hour timer mode: press and hold the button until the lamp(s) turn ON.

To change the operation to minute timer mode: press and hold the button until the lamp(s) turn OFF.

(Minute timer mode is the default)

To cancel/exit do nothing for 30 seconds.

5. Click once to save & exit.

The hour or minute operating function of LEDsmart+ timers connected in parallel must be set individually. A change of timer type is not automatically set across units.

Adjust!

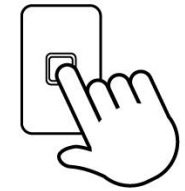

G: SETTING MULTIMATE™ MODE

1. Enter the timer **Setup Mode** - See **PART A**.

Setup Mode!



2. Click the push button **8 times**.



3. The LED will blink 8 times.

If the MultiMate™ function is currently Disabled, lamp(s) connected to the dimmer will now turn OFF.

If the MultiMate™ function is currently Enabled, lamps(s) connected to the dimmer will now turn ON.

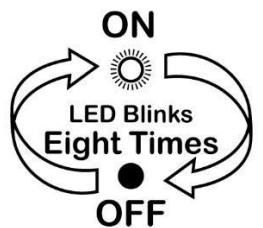

4. To Enable MultiMate™ (Default) push-and-hold the button until the lamp(s) turns ON.

To Disable MultiMate™ push-and-hold the button until the lamp(s) turns OFF.

To cancel/exit do nothing for 30 seconds.

5. Click once to save & exit.

MultiMate™ mode for LEDsmart+ timers connected in parallel must be set individually. A change of mode is not automatically set across units.

Adjust!

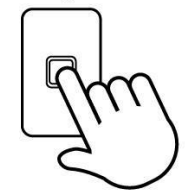

H: RESETTING TO FACTORY DEFAULT

1. Enter the timer **Setup Mode** - See **PART A**.

Setup Mode!



2. Click the push button **10 times**.



3. The timer will automatically exit Setup Mode when it has reset.

This product has a **TWO YEAR** warranty against manufacturing defects in addition to relevant consumer law guarantees. Refer to pierlite.com for our full warranty conditions, or phone customer service.

Clipsal Saturn™ and Clipsal Saturn Zen™ are trademarks of Schneider Electric (Australia) Pty Ltd

© Copyright

This user and installation guide is copyright to Signify Innovations Australia Pty Ltd. Except as permitted under relevant law, no part of this user and installation guide may be reproduced by any process without written permission of and acknowledgement to Signify Innovations Australia Pty Ltd.

Signify Innovations Australia Pty Ltd reserves the right to alter the specifications, designs or other features of any items and to discontinue any items at any time without notice and without liability. While every effort is made to ensure that all information in this user and installation guide is correct, no warranty of accuracy is given and Signify Innovations Australia Pty Ltd shall not be liable for any error.

DIGINET and PIERLITE are brands of Signify Innovations Australia Pty Ltd (ABN 74 619 622 196). 96-112 Gow Street, Padstow NSW 2211, Australia.

DIGINET and PIERLITE are brands of Signify New Zealand Limited. 686A Rosebank Road, Avondale, Auckland 1026, New Zealand.

Customer Service: AU: 1300 799 300 | NZ 0508 743 754
International: +61 2 9353 9417

www.pierlite.com