

A large, stylized green emergency exit sign is the background of the page. It features a white silhouette of a person running towards the right, with a white arrow pointing in the same direction. The sign is set against a dark green background.

# EMERGENCY LIGHTING SOLUTIONS

VERSION 3

# WHEN IT COMES TO EMERGENCY LIGHTING NO OTHER COMPANY DELIVERS LIKE PIERLITE.

With a 70-year history synonymous with the evolution of the lighting industry, we are recognised as the market leader in Australasia for the design, manufacture and distribution of commercial, industrial and healthcare lighting systems.

We have sales and customer service in each capital city of Australia, and an expanding global network of brands. We are continually exploring insights and ideas that push the limits of what's possible. As the trusted partner for project managers, architects, electrical contractors and consultants we deliver:

- Inspired lighting expertise with access to lighting consultants and engineers
- Complete lighting solutions from consultation and design through to delivery
- An innovative portfolio of products built to Australian standards and compliance regulations
- Australia's only state-of-the-art Innovation Lab/Centre, an engineering and product development facility
- In-house quality control and testing on all products and technical support services

## SOLUTIONS FOCUSED WITH PROVEN RESULTS

Our proven capabilities have resulted in the delivery of innovative and sustainable emergency lighting solutions, to multi-disciplined segments including:

**Commercial | Industrial | Healthcare**



**COMMERCIAL**



**INDUSTRIAL**

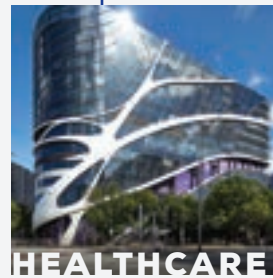

**HEALTHCARE**

# CONTENTS

|   |           |  |           |
|---|-----------|--|-----------|
| <b>STANDARD EMERGENCY:<br/>EXIT SIGNS</b> | <b>6</b>  | <b>SELF TEST / DALI EMERGENCY:<br/>EXIT SIGNS</b>          | <b>30</b> |
| Director 2 LED Exit Light                 | 7         | Weatherlux Exit Light Gen2                                 | 31        |
| Blade 2 LED Exit Light                    | 8         | Blade 2 DALI LED Exit Light                                | 32        |
| Stingray 2 LED Exit Light                 | 9         | Stingray 2 DALI LED Exit Light                             | 33        |
| Arctic 2 LED Exit Light                   | 10        | Warden 2 DALI LED Exit Light                               | 34        |
| Baci 2 LED Exit Light                     | 11        | Jumbo 2 DALI LED Exit Light                                | 35        |
| Jumbo 2 LED Exit Light                    | 12        |  |           |
| <b>STANDARD EMERGENCY:<br/>LUMINAIRES</b> | <b>13</b> | <b>SELF TEST / DALI EMERGENCY:<br/>EMERGENCY</b>           | <b>36</b> |
| Firefly 2 LED Emergency Light             | 14        | Guardian 2 DALI LED Emergency Floodlight                   | 37        |
| Guardian 2 LED Emergency Floodlight       | 15        | Pathfinder ECO DALI LED Emergency Light                    | 38        |
| Pathfinder ECO LED Emergency Light        | 16        | Pathfinder 2 DALI LED Emergency Light                      | 39        |
| Pathfinder 2 LED Emergency Light          | 17        | Pathfinder 2 Weatherproof<br>Emergency Light               | 40        |
| Emergency Conversion Kit                  | 18        |  |           |
| Polo2 Oyster Emergency Light              | 19        | <b>SELF TEST / DALI EMERGENCY:<br/>LINEAR</b>              | <b>41</b> |
| <b>STANDARD EMERGENCY:<br/>LINEAR</b>     | <b>20</b> | BWP Pro 2 LED Emergency<br>Weatherproof Batten             | 42        |
| ECO LED Emergency Batten Gen 3            | 21        | SDW 2 LED Emergency Batten                                 | 44        |
| Nipper LED Emergency Batten               | 22        | Vandalux LED Emergency<br>Weatherproof Batten              | 46        |
| BWP Construction LED Emergency Batten     | 23        | Vandaguard LED Emergency<br>Weatherproof Batten            | 48        |
| BWP ECO LED Emergency Batten              | 24        |  |           |
| <b>STANDARD EMERGENCY:<br/>BULKHEADS</b>  | <b>26</b> | <b>SELF TEST / DALI EMERGENCY:<br/>POST TOPS/BULKHEADS</b> | <b>49</b> |
| Deco LED Emergency Bulkhead               | 27        | Mine Master LED Emergency<br>Post Top Gen2                 | 50        |
|   |           | Alien LED Emergency Post Top Gen2                          | 51        |
|   |           | Nexus LED Emergency Bulkhead Gen2                          | 52        |

## OUR INDUSTRY PARTNERS





# PIERLITE EMERGENCY EXIT AND LUMINAIRES PROVIDE — A SOLUTION FOR ANY APPLICATION AND LOCATION.

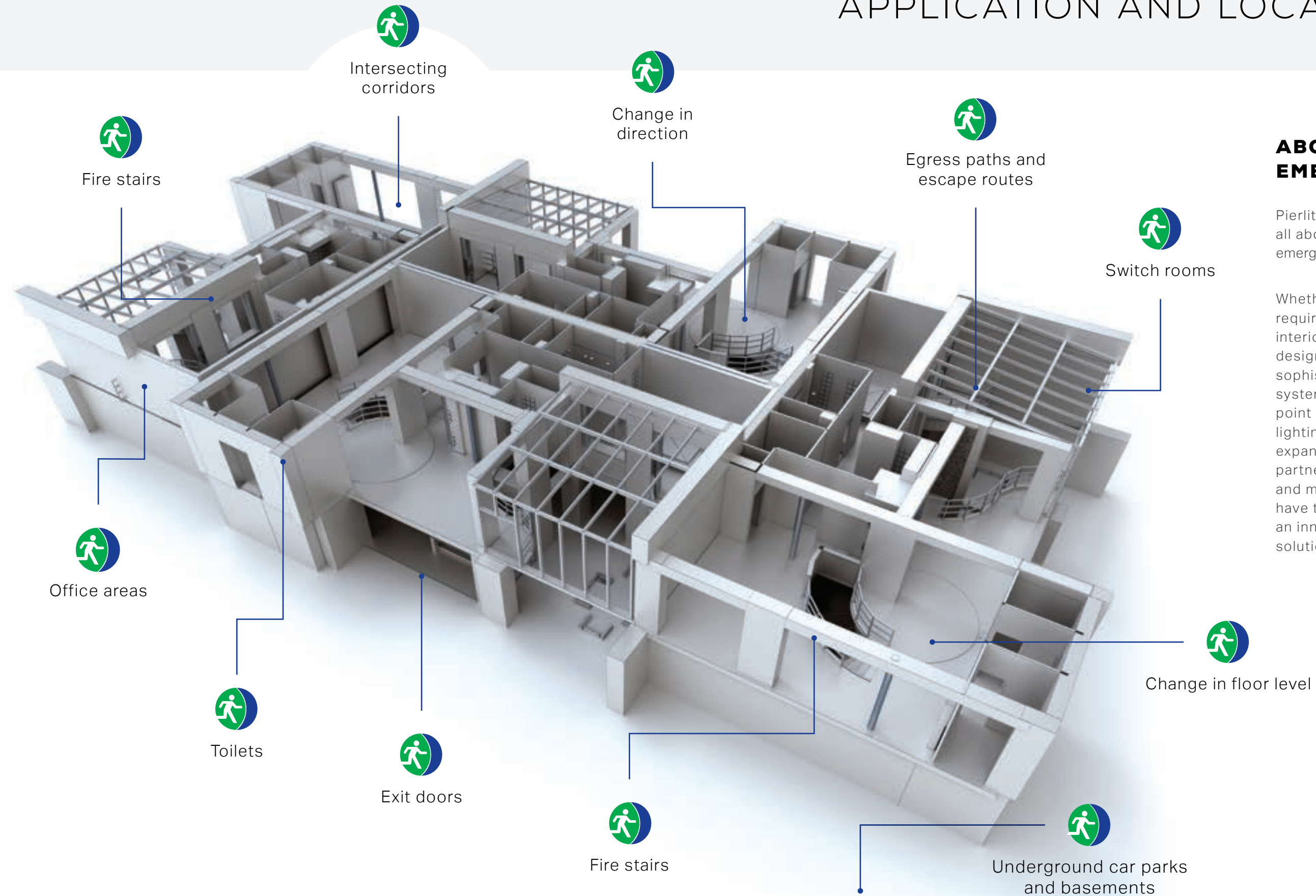

## ABOUT EMERGENCY

Pierlite's emergency range is all about creating a sustainable emergency lighting solution for you.

Whether your design requirements demand a unique interior or exterior commercial design, incorporating sophisticated DALI monitored systems or traditional single point functions; our emergency lighting solution with an expansive suite of international partners, Australian design and manufacturing resources, have the experience to create an innovative and sustainable solution for you.



STANDARD EMERGENCY  
**EXIT SIGNS**

# DIRECTOR 2 LED EXIT LIGHT

COMPLETE WITH LITHIUM IRON PHOSPHATE BATTERY

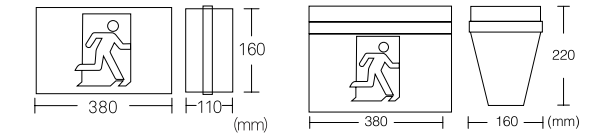

All pictogram inserts

## FEATURES

- Ceiling or wall mountable for flexibility
- One-box solution, including all pictogram inserts
- DALI version available
- 24m viewing distance
- Complete with replaceable Lithium Iron Phosphate (LiFePO4) battery
- 3 year warranty, including battery
- Compliant to AS/NZS 2293

## SPECIFICATIONS

- Wattage: Maximum 4.6W
- Lumens: 48lm @ 1W
- Voltage: 240V
- Ingress Protection: IP20 rated
- Operating Temperature: 0°C to 40°C
- Lifetime: 50,000hrs (L70/B50)
- Colour: White
- Emergency Test/Operation: Manual/maintained
- Battery Specification: LiFePO4 battery, 1 cell 3.2V 1500mAh
- Emergency Classification:
  - DIRLEDPSSL (wall mounted): C0:E1 C90/C270:E1.25
  - DIRLEDPDSL (ceiling mounted): C0/C180:D5 C90/C270:D6.3

## APPLICATIONS

Ideal as a general purpose traditional interior exit luminaire, for commercial or retail buildings.

**DIRLEDPSSL - WALL MOUNT:**  
AS/NZS 2293.1:2018 CLASSIFICATION TABLE

| ALLOWABLE LUMINAIRE MOUNTING HEIGHT (M) | LUMINAIRE MAXIMUM SPACING FOR EACH PLANE (M) |     |      |      |
|---|--|-----|------|------|
|   | C0   | C90 | C180 | C270 |
| 2.1                                     | 3.7  | 4.1 | 0    | 4.1  |
| 2.4                                     | 0  | 4.1 | 0    | 4.1  |
| 2.7                                     | 0  | 0   | 0    | 0    |

**DIRLEDPDSL - CEILING MOUNT:**  
AS/NZS 2293.1:2018 CLASSIFICATION TABLE

| ALLOWABLE LUMINAIRE MOUNTING HEIGHT (M) | LUMINAIRE MAXIMUM SPACING FOR EACH PLANE (M) |     |      |      |
|---|--|-----|------|------|
|   | C0   | C90 | C180 | C270 |
| 2.1                                     | 7.8  | 4.1 | 0    | 8.5  |
| 2.4                                     | 8  | 4.1 | 0    | 8.8  |
| 2.7                                     | 8.1  | 0   | 0    | 8.9  |

| PRODUCT CODE | DESCRIPTION                         | WATTAGE (W) | DIMENSION (MM)        | MASS (KG) |
|--------------|-------------------------------------|-------------|-----------------------|-----------|
| DIRLEDPSSL   | Director 2 Wall Mount Exit Light    | 4.6 (max)   | L 380 x W 110 x H 160 | 1.3       |
| DIRLEDPDSL   | Director 2 Ceiling Mount Exit Light | 4.6 (max)   | L 380 x W 160 x H 220 | 1.3       |

## ACCESSORY CODE

|                |                                      |
|----------------|--------------------------------------|
| BATPK1500/1L11 | LiFePO4 Battery, 1 Cell 3.2V 1500mAh |
|----------------|--------------------------------------|



# BLADE 2 LED EXIT LIGHT

COMPLETE WITH LITHIUM IRON PHOSPHATE BATTERY

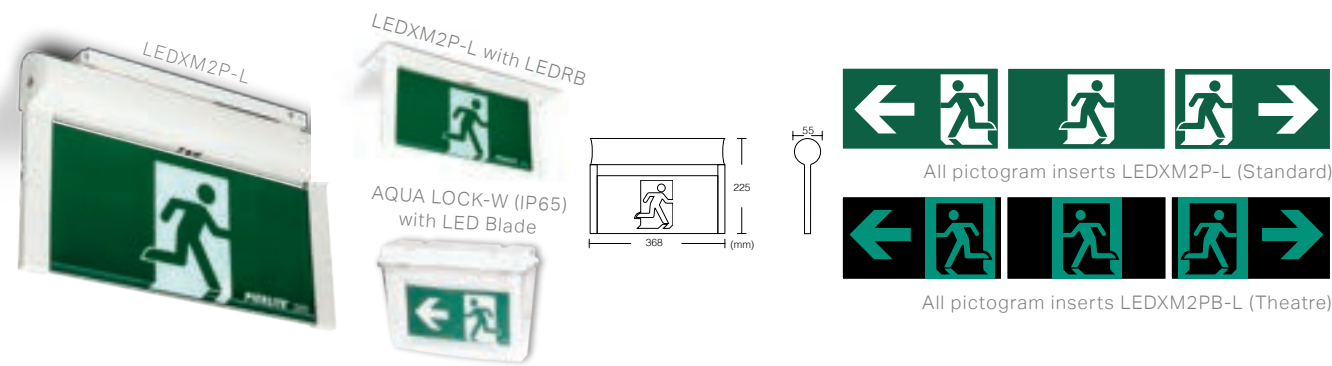

## FEATURES

- Ceiling mount, with optional wall mount and recessed kit
- Available in a black theatre version
- Optional IP65 Enclosure (Aqualock)
- One-box solution, including all pictogram inserts
- DALI version available
- 24m viewing distance
- Complete with replaceable Lithium Iron Phosphate (LiFePO4) battery
- 3 year warranty, including battery
- Compliant to AS/NZS 2293

## APPLICATIONS

Ideal for emergency lighting applications where aesthetics are important - commercial buildings, hotels, retail, cinema complexes, apartments and hospitals.

## OPTIONAL ACCESSORIES

IP65 Enclosure, recessed kit (white/black), suspension kit and cantilever bracket wall mount kit.

## SPECIFICATIONS

- Wattage: Maximum 4.6W
- Lumens: 30lm @ 0.9W
- Voltage: 240V
- Ingress Protection: IP20 rated and optional IP65 kit
- Operating Temperature: 0°C to 40°C
- Lifetime: 50,000hrs (L70/B50)
- Colour: White/black
- Emergency Test/Operation: Manual/maintained
- Battery Specification: LiFePO4 battery, 1 cell 3.2V 1500mAh
- Emergency Classification:
  - LEDXM2P-L (Standard): C0/C180:D4 & C90/C270:E3.2 (2hr)
  - LEDXM2PB-L (Theatre): C0/C180: E1.6 & C90/C270:E2 (2hr)

LEDXM2P-L (STANDARD):  
AS/NZS 2293.1:2018 CLASSIFICATION TABLE

| ALLOWABLE LUMINAIRE MOUNTING HEIGHT (M) | LUMINAIRE MAXIMUM SPACING FOR EACH PLANE (M) |          |
|---|--|----------|
|   | C0/C180                                      | C90/C270 |
| 2.1                                     | 7.1  | 5.8      |
| 2.4                                     | 7.2  | 6.1      |
| 2.7                                     | 7.3  | 6.4      |

LEDXM2PB-L (THEATRE):  
AS/NZS 2293.1:2018 CLASSIFICATION TABLE

| ALLOWABLE LUMINAIRE MOUNTING HEIGHT (M) | LUMINAIRE MAXIMUM SPACING FOR EACH PLANE (M) |          |
|---|--|----------|
|   | C0/C180                                      | C90/C270 |
| 2.1                                     | 4.6  | 5        |
| 2.4                                     | 4.7  | 5.2      |
| 2.7                                     | 4.6  | 5.2      |

| PRODUCT CODE | DESCRIPTION                      | WATTAGE (W) | DIMENSION (MM)       | MASS (KG) |
|--------------|----------------------------------|-------------|----------------------|-----------|
| LEDXM2P-L    | Standard Blade 2 Exit Light      | 4.6 (max)   | L 368 x W 55 x H 225 | 0.9       |
| LEDXM2PB-L   | Theatre/Black Blade 2 Exit Light | 4.6 (max)   | L 368 x W 55 x H 225 | 0.9       |

### ACCESSORY CODE

|                |  |
|----------------|--|
| BATPK1500/1L11 | LiFePO4 Battery, 1 Cell 3.2V 1500mAh             |
| AQUALOCK-W     | IP65 Enclosure                                   |
| LEDRB          | Recessed Bracket White (cut-out: L 380 x W 88mm) |
| LEDRBBK        | Recessed Bracket Black                           |
| SKITLED        | Suspension Kit                                   |
| EXCB           | Cantilever Bracket Wall Mount Kit                |

# STINGRAY 2 LED EXIT LIGHT

COMPLETE WITH LITHIUM IRON PHOSPHATE BATTERY

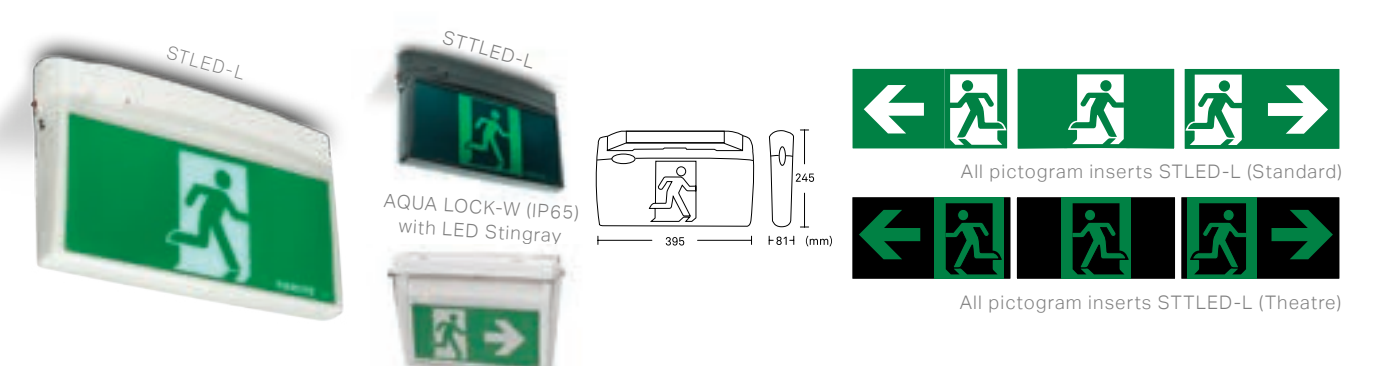

## FEATURES

- Ceiling mount, with optional wall mount kit
- Available in a black theatre version
- Optional IP65 Enclosure (Aqualock)
- One-box solution, including all pictogram inserts
- DALI version available
- 24m viewing distance
- Complete with replaceable Lithium Iron Phosphate (LiFePO4) battery
- 3 year warranty, including battery
- Compliant to AS/NZS 2293

## APPLICATIONS

Commercial and apartment buildings, retail, cinemas and halls.

## OPTIONAL ACCESSORIES

IP65 enclosure, rod suspension kit, cantilever bracket wall mount kit.

## SPECIFICATIONS

- Wattage: Maximum 4.6W
- Lumens: 27lm @ 1W
- Voltage: 240V
- Ingress Protection: IP20 rated and optional IP65 kit
- Operating Temperature: 0°C to 40°C
- Lifetime: 50,000hrs (L70/B50)
- Colour: White/black
- Emergency Test/Operation: Manual/maintained
- Battery Specification: LiFePO4 battery, 1 cell 3.2V 1500mAh
- Emergency Classification:
  - STLED-L (Standard): C0/C180:D3.2 & C90/C270:E2
  - STTLED-L (Theatre): C0/C180: E1.6 C90/C270:E2

STLED-L (STANDARD):  
AS/NZS 2293.1:2018 CLASSIFICATION TABLE

| ALLOWABLE LUMINAIRE MOUNTING HEIGHT (M) | LUMINAIRE MAXIMUM SPACING FOR EACH PLANE (M) |          |
|---|--|----------|
|   | C0/C180                                      | C90/C270 |
| 2.1                                     | 6.5  | 5        |
| 2.4                                     | 6.5  | 5.2      |
| 2.7                                     | 6.5  | 5.2      |

STTLED-L (THEATRE):  
AS/NZS 2293.1:2018 CLASSIFICATION TABLE

| ALLOWABLE LUMINAIRE MOUNTING HEIGHT (M) | LUMINAIRE MAXIMUM SPACING FOR EACH PLANE (M) |          |
|---|--|----------|
|   | C0/C180                                      | C90/C270 |
| 2.1                                     | 4.6  | 5        |
| 2.4                                     | 4.7  | 5.2      |
| 2.7                                     | 4.6  | 5.2      |

| PRODUCT CODE | DESCRIPTION                         | WATTAGE (W) | DIMENSION (MM)       | MASS (KG) |
|--------------|-------------------------------------|-------------|----------------------|-----------|
| STLED-L      | Standard Stingray 2 Exit Light      | 4.6 (max)   | L 395 x W 81 x H 245 | 1.2       |
| STTLED-L     | Theatre/Black Stingray 2 Exit Light | 4.6 (max)   | L 395 x W 81 x H 245 | 1.2       |

### ACCESSORY CODE

|                |  |
|----------------|--|
| BATPK1500/1L11 | LiFePO4 Battery, 1 Cell 3.2V 1500mAh             |
| AQUALOCK-W     | IP65 Enclosure                                   |
| LEDRB          | Recessed Bracket White (cut-out: L 380 x W 88mm) |
| LEDRBBK        | Recessed Bracket Black                           |
| EXCB           | Cantilever Bracket Wall Mount Kit                |

# ARCTIC 2 LED EXIT LIGHT

WITH HIGH TEMPERATURE NICKEL CADMIUM BATTERY



## FEATURES

- Ceiling or wall mountable with single or double-sided options all in one box (mounting bracket included)
- Heavy duty IK10 die-cast aluminium housing and a vandal resistant UV stable polycarbonate lens
- Minimum temperature of -30 °C available, making it suitable for severe environments
- 24m viewing distance
- High temperature Nickel Cadmium battery
- 2 year warranty, including battery
- Compliant to AS/NZS 2293

## APPLICATIONS

Food processing facilities, outdoor parking garages, walk in freezers, indoor/outdoor severe environments.

### ARCTIC-FR AND ARCTIC SINGLE AND DOUBLE SIDED: AS/NZS 2293.1:2018 CLASSIFICATION TABLE

| ALLOWABLE LUMINAIRE MOUNTING HEIGHT (M) | LUMINAIRE MAXIMUM SPACING FOR EACH PLANE (M) |          |      |
|---|--|----------|------|
|   | C0   | C90/C270 | C180 |
| 2.1                                     | 4.6  | 4.6      | 4.6  |
| 2.4                                     | 4.7  | 4.7      | 4.7  |
| 2.7                                     | 4.6  | 4.6      | 4.6  |
| 3                                       | 0  | 0        | 0    |
| 3.3                                     | 0  | 0        | 0    |
| 3.6                                     | 0  | 0        | 0    |
| 4                                       | 0  | 0        | 0    |

## SPECIFICATIONS

- Wattage: Maximum 4W
- Lumens: 41lm @ 2.6W
- Voltage: 240V
- Ingress Protection: IP66 rated
- Impact Rating: IK10
- Operating Temperature:
  - ARCTIC-FR: -30 °C to 40 °C
  - ARCTIC: -10 °C to 40 °C
- Lifetime: 50,000hrs (L70/B50)
- Colour: White
- Emergency Test/Operation: Manual/maintained
- Battery Specification: NiCd battery, 4 cell 4.8V 1800mAh
- Emergency Classification:
  - ARCTIC-FR and ARCTIC single and double sided: C0/C180:E1.6 & C90/C270:E1.6

# BACI 2 LED EXIT LIGHT

COMPLETE WITH LITHIUM IRON PHOSPHATE BATTERY

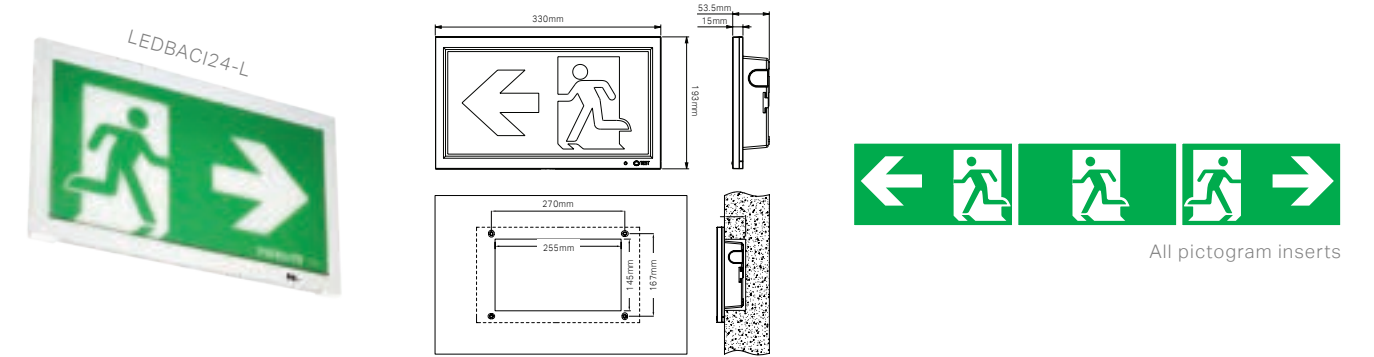

## FEATURES

- Wall recessed or wall surface mount
- One-box solution, including all pictogram inserts
- 24m viewing distance
- Complete with replaceable Lithium Iron Phosphate (LiFePO4) battery
- 3 year warranty including battery
- Compliant to AS/NZS 2293

## APPLICATIONS

Ideal for commercial and interior applications, apartment buildings, retail, cinemas and halls.

## SPECIFICATIONS

- Wattage: Maximum 4.6W
- Lumens: 27lm @ 1W
- Voltage: 240V
- Ingress Protection: IP20 rated
- Operating Temperature: 10 °C to 40 °C
- Lifetime: 50,000hrs (L70/B50)
- Colour: White
- Emergency Test/Operation: Manual/maintained
- Battery Specification: LiFePO4 battery, 1 Cell 3.2V 1500mAh

| PRODUCT CODE | DESCRIPTION                     | WATTAGE (W) | DIMENSION (MM)         | MASS (KG) |
|--------------|---------------------------------|-------------|------------------------|-----------|
| LEDBACI24-L  | Baci 2 Wall Recessed Exit Light | 4.6 (max)   | L 330 x H 193 x W 53.5 | 1.2       |

| ACCESSORY CODE | DESCRIPTION                          |
|----------------|--------------------------------------|
| BATPK1500/1L11 | LiFePO4 Battery, 1 Cell 3.2V 1500mAh |

| PRODUCT CODE | DESCRIPTION  | WATTAGE (W) | OPERATING TEMPERATURE (°C) | DIMENSION (MM)        | MASS (KG) |
|--------------|--|-------------|----------------------------|-----------------------|-----------|
| ARCTIC       | Arctic 2 Exit Light  | 4 (max)     | -10 °C to 40 °C            | L 350 x W 100 x H 210 | 4.7       |
| ARCTIC-FR    | Arctic 2 Exit Freezer Light  | 4 (max)     | -30 °C to 40 °C            | L 350 x W 100 x H 210 | 4.7       |
| ARCTICPSL    | Decal Left Insert (decals not included and must be ordered separately)     |             |                            |                       |           |
| ARCTICPSR    | Decal Right Insert (decals not included and must be ordered separately)    |             |                            |                       |           |
| ARCTICPSS    | Decal Straight Insert (decals not included and must be ordered separately) |             |                            |                       |           |

Note: Single/double sided options included. Mounting bracket for wall and ceiling included.

# JUMBO 2 LED EXIT LIGHT

COMPLETE WITH LITHIUM IRON PHOSPHATE BATTERY

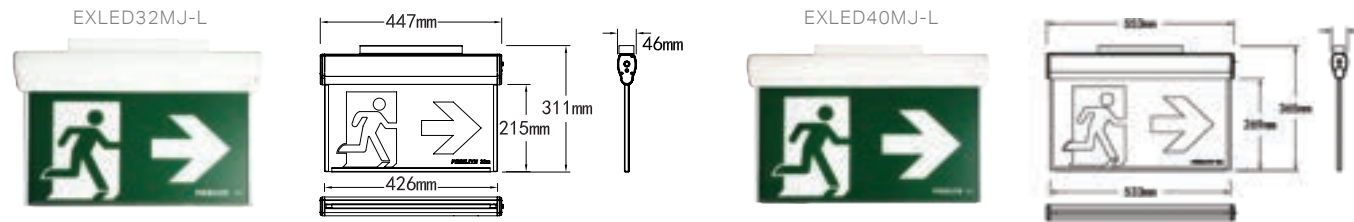

## FEATURES

- Ceiling or wall mountable for flexibility
- One-box solution, including all pictogram inserts
- Available in 32m and 40m viewing distance options
- Complete with replaceable Lithium Iron Phosphate (LiFePO4) battery
- 3 years warranty including battery
- Compliant to AS/NZS 2293

## SPECIFICATIONS

- Wattage: Maximum 7W (32M) and 7.5W (40M)
- Lumens: 190lm @ 2.2W
- Voltage: 240V
- Ingress Protection: IP20 rated
- Operating Temperature: 0°C to 40°C
- Lifetime: 50,000hrs (L70/B50)
- Colour: White
- Emergency Test/Operation: Manual/maintained
- Battery Specification: LiFePO4 battery, 2 cell 6.4V 1500mAh
- Emergency Classification:
  - Jumbo 32M: C0/C180:D16 & C90/C270: C50 (2hr)
  - Jumbo 40M: C0/C180:C50 & C90/C270: C40 (2hr)

## APPLICATIONS

Ideal for large open areas where aesthetics are important - commercial buildings, airports, hotels, retail, apartments and hospitals.

**EXLED32MJ-L:**  
AS/NZS 2293.1:2018 CLASSIFICATION TABLE

| ALLOWABLE LUMINAIRE MOUNTING HEIGHT (M) | LUMINAIRE MAXIMUM SPACING FOR EACH PLANE (M) |          |
|---|--|----------|
|   | C0/C180                                      | C90/C270 |
| 2.1                                     | 11.5   | 11.3     |
| 2.4                                     | 12.5   | 12       |
| 2.7                                     | 12.9   | 12.7     |
| 3                                       | 13.3   | 13.4     |

**EXLED40MJ-L:**  
AS/NZS 2293.1:2018 CLASSIFICATION TABLE

| ALLOWABLE LUMINAIRE MOUNTING HEIGHT (M) | LUMINAIRE MAXIMUM SPACING FOR EACH PLANE (M) |          |
|---|--|----------|
|   | C0/C180                                      | C90/C270 |
| 2.1                                     | 11.3   | 10.6     |
| 2.4                                     | 12   | 11.3     |
| 2.7                                     | 12.7   | 12       |
| 3                                       | 13.4   | 12.6     |

| PRODUCT CODE | DESCRIPTION            | WATTAGE (W) | DIMENSION (MM)       | MASS (KG) |
|--------------|------------------------|-------------|----------------------|-----------|
| EXLED32MJ-L  | Jumbo 2 32M Exit Light | 7 (max)     | L 426 x H 311 x W 46 | 1.8       |
| EXLED40MJ-L  | Jumbo 2 40M Exit Light | 7.5 (max)   | L 533 x H 365 x W 46 | 2         |

## ACCESSORY CODE

|                |                                      |
|----------------|--------------------------------------|
| BATPK1500/2L12 | LiFePO4 Battery, 2 Cell 6.4V 1500mAh |
|----------------|--------------------------------------|

STANDARD EMERGENCY

# LUMINAIRES

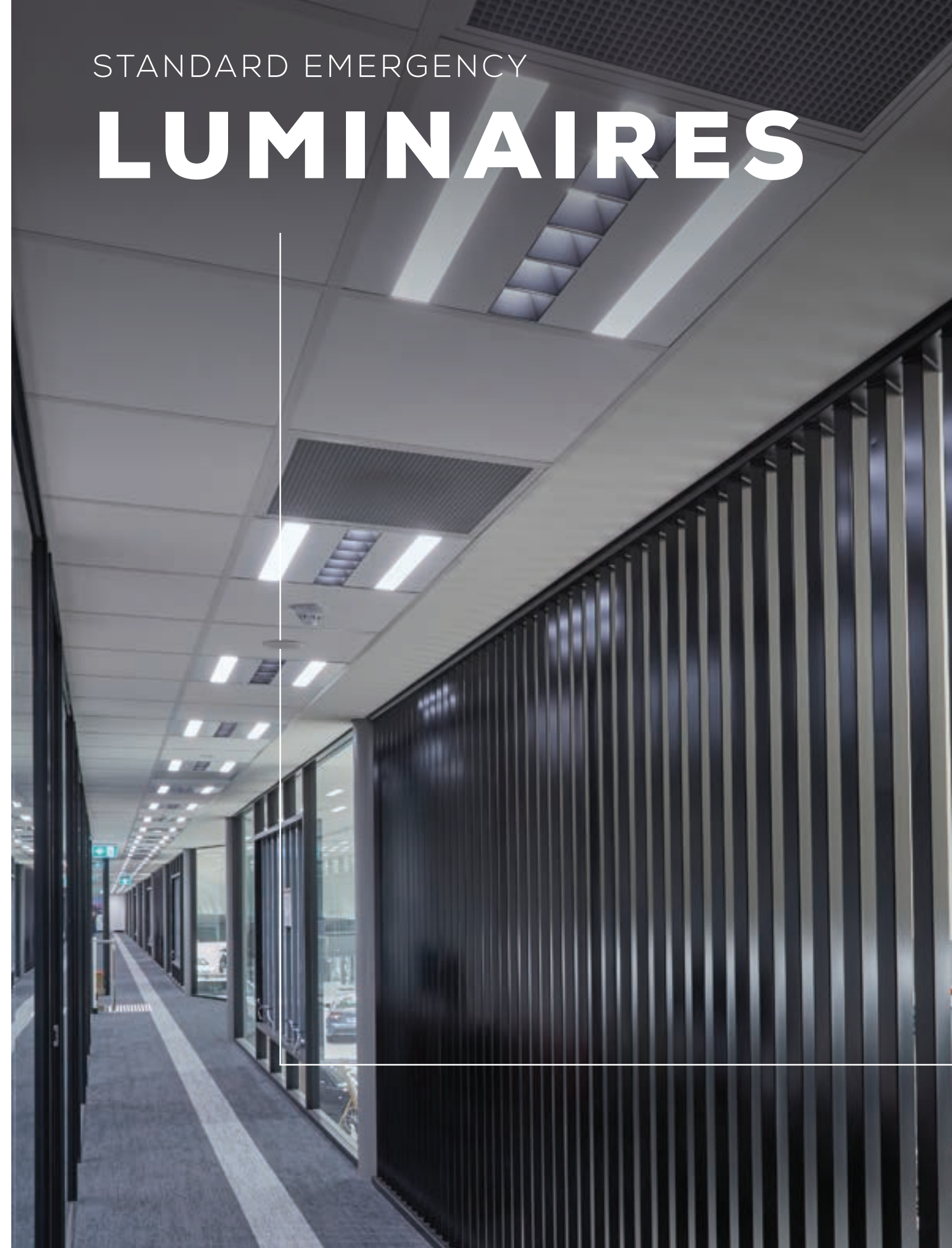



# FIREFLY 2 LED EMERGENCY LIGHT

COMPLETE WITH LITHIUM IRON PHOSPHATE BATTERY



## FEATURES

- Recessed mount with an optional surface mount kit
- Flex and plug included for easy installation
- Available in white or black
- Complete with replaceable Lithium Iron Phosphate (LiFePO4) battery
- 3 year warranty including battery
- Compliant to AS/NZS 2293

## APPLICATIONS

All commercial and interior applications, apartments, shopping centres, hospitality, prisons and hospitals.

FFRLED2 AND FFRLEDBK2:  
AS/NZS 2293.1:2018 CLASSIFICATION TABLE

| ALLOWABLE LUMINAIRE MOUNTING HEIGHT (M) | LUMINAIRE MAXIMUM SPACING FOR EACH PLANE (M) |          |      |
|---|--|----------|------|
|   | C0   | C90/C270 | C180 |
| 2.1                                     | 11.5   | 11.5     | 11.5 |
| 2.4                                     | 13.2   | 13.2     | 13.2 |
| 2.7                                     | 14.8   | 14.8     | 14.8 |
| 3                                       | 16.5   | 16.5     | 16.5 |
| 3.3                                     | 17.6   | 17.6     | 17.6 |
| 3.6                                     | 18   | 18       | 18   |
| 4                                       | 18.5   | 18.5     | 18.5 |
| 4.5                                     | 19   | 19       | 19   |
| 5                                       | 19.5   | 19.5     | 19.5 |
| 6                                       | 20.1   | 20.1     | 20.1 |

| PRODUCT CODE | DESCRIPTION                     | WATTAGE (W) | DIMENSION (MM) | MASS (KG) |
|--------------|---------------------------------|-------------|----------------|-----------|
| FFRLED2      | Firefly 2 Emergency Light White | 2.5 (max)   | Ø 140 x H 48.5 | 0.48      |
| FFRLEDBK2    | Firefly 2 Emergency Light Black | 2.5 (max)   | Ø 140 x H 48.5 | 0.48      |

## ACCESSORY CODE

|                |                                      |
|----------------|--------------------------------------|
| BATPK1200/4L41 | LiFePO4 battery, 4 cell 6.4V 1200mAh |
| FFSLEDKITWH    | Surface Mount Kit White              |
| FFSLEDKITBK    | Surface Mount Kit Black              |

## OPTIONAL ACCESSORIES

Surface mount kits in white and black.

## SPECIFICATIONS

- Wattage: Maximum 2.5W
- Lumens: 174lm (93lm/W)
- Voltage: 240V
- Ingress Protection: IP20 rated
- Operating Temperature: 0°C to 40°C
- Lifetime: 50,000hrs (L70/B50)
- Colour: White/black
- Material: Polycarbonate
- Emergency Test/Operation: Manual/non-maintained
- Battery Specification: LiFePO4 battery, 4 cell 6.4V 1200mAh
- Emergency Classification: D32

# GUARDIAN 2 LED EMERGENCY FLOODLIGHT

COMPLETE WITH LITHIUM IRON PHOSPHATE BATTERY



## FEATURES

- Adjustable twin head floodlight for wall or ceiling surface mounting
- Non corrosive polycarbonate housing and reflectors
- DALI version also available
- Complete with replaceable Lithium Iron Phosphate (LiFePO4) battery
- 3 year warranty including battery
- Compliant to AS/NZS 2293

## APPLICATIONS

Ideal for interior commercial/ industrial spaces, retail stores, public auditoriums, warehouse facilities, factories, airports and school halls.

## OPTIONAL ACCESSORIES

IP65 enclosure.

| PRODUCT CODE | DESCRIPTION                                    | WATTAGE (W) | LUMENS (LM)                  | DIMENSION (MM)  | MASS (KG) |
|--------------|--|-------------|------------------------------|-----------------|-----------|
| GRLED7FL-L   | Guardian 2 Non-Maintained Emergency Floodlight | 4 (max)     | 308lm per head (total 616lm) | L 350xW 80xH 80 | 1         |

## ACCESSORY CODE

|                |                                      |
|----------------|--------------------------------------|
| BATPK3200/2L21 | LiFePO4 battery, 2 cell 6.4V 3200mAh |
| GRWPENCL       | IP65 enclosure                       |

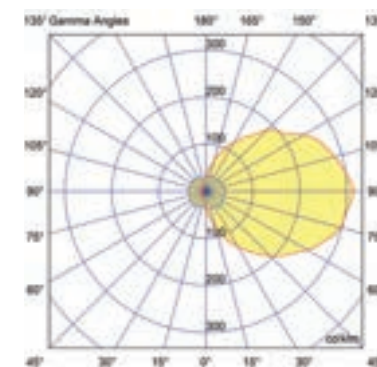

## POLAR GRAPH

1. Represents only one LED adjustable head and the true lumens will result in 2 times 308 (total lumens: 616lm)
2. Emergency flood units cannot be issued with an AS/NZS 2293.1:2018 spacing table classification as they have adjustable heads (not fixed)
3. Specifiers note: IES files are available for lighting design calculations



# PATHFINDER ECO LED EMERGENCY LIGHT



COMPLETE WITH LITHIUM IRON PHOSPHATE BATTERY



## FEATURES

- Available in recessed or ceiling surface mount
- Flex and plug included for easy installation
- DALI version also available
- Complete with Lithium Iron Phosphate (LiFePO4) battery
- 3 year warranty, including battery
- Compliant to AS/NZS 2293

## APPLICATIONS

All commercial and interior applications, apartments, shopping centres, hospitality, and hospitals.

PFLED-ECO, PFLED-ECO-SF:  
AS/NZS 2293.1:2018 CLASSIFICATION TABLE

| ALLOWABLE LUMINAIRE MOUNTING HEIGHT (M) | LUMINAIRE MAXIMUM SPACING FOR EACH PLANE (M) |          |      |
|---|--|----------|------|
|   | C0   | C90/C270 | C180 |
| 2.1                                     | 11.5   | 11.5     | 11.5 |
| 2.4                                     | 13.2   | 13.2     | 13.2 |
| 2.7                                     | 14.8   | 14.8     | 14.8 |
| 3                                       | 16.5   | 16.5     | 16.5 |
| 3.3                                     | 18.1   | 18.1     | 18.1 |
| 3.6                                     | 19.5   | 19.5     | 19.5 |
| 4                                       | 20.1   | 20.1     | 20.1 |
| 4.5                                     | 20.7   | 20.7     | 20.7 |
| 5                                       | 21.2   | 21.2     | 21.2 |
| 6                                       | 22.1   | 22.1     | 22.1 |
| 7                                       | 22.6   | 22.6     | 22.6 |

## OPTIONAL ACCESSORIES

Surface mount kit and recessed vandal kit.

## SPECIFICATIONS

- Wattage: Maximum 1.5W
- Lumens: 217lm
- Voltage: 240V
- Ingress Protection: IP20 rated
- Operating Temperature: 0 °C to 40 °C
- Lifetime: 50,000hrs (L70/B50)
- Colour: White
- Material: Polycarbonate
- Emergency Test/Operation: Manual/non-maintained
- Battery Specification: LiFePO4 battery, 1 cell 3.2V 1500mAh
- Emergency Classification: C0/C180:D40 & C90/C270:D40

| PRODUCT CODE | DESCRIPTION                                  | WATTAGE (W) | DIMENSION (MM)       | MASS (KG) |
|--------------|--|-------------|----------------------|-----------|
| PFLED-ECO    | Pathfinder ECO Recessed Emergency Light      | 1.5 (max)   | Ø 140 x H 34         | 0.3       |
| PFLED-ECO-SF | Pathfinder ECO Surface Mount Emergency Light | 1.5 (max)   | L 214 x W 214 x H 60 | 0.36      |

## ACCESSORY CODE

|           |                                |
|-----------|--------------------------------|
| PFSKIT-L2 | Pathfinder 2 Surface Kit White |
| FFLEDVK   | Recessed Vandal Kit            |

# PATHFINDER 2 LED EMERGENCY LIGHT



COMPLETE WITH LITHIUM IRON PHOSPHATE BATTERY

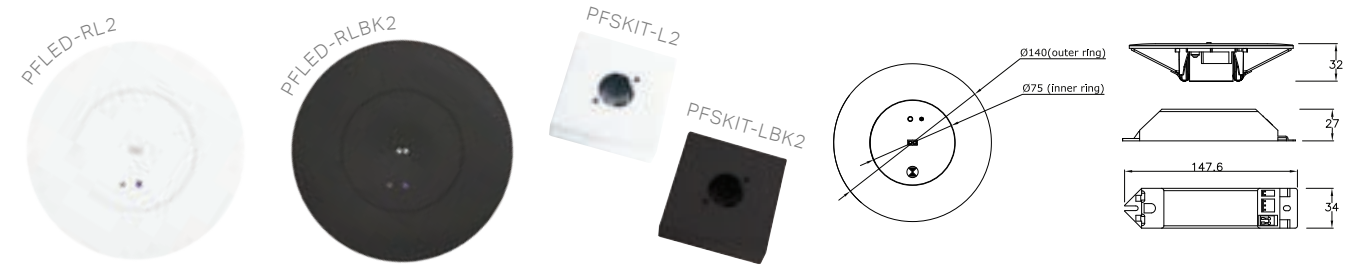

## FEATURES

- High luminous efficacy to maximise spacing
- Recessed mount with optional surface mount kit
- Available in white and black versions
- Flex and plug included for easy installation
- DALI version also available
- Complete with replaceable Lithium Iron Phosphate (LiFePO4) battery
- 4 year warranty including battery
- Compliant to AS/NZS 2293

## APPLICATIONS

All commercial and interior applications, apartments, shopping centres, hospitality, prisons and hospitals.

## OPTIONAL ACCESSORIES

Surface mount kit in black/white and recessed vandal kit.

## SPECIFICATIONS

- Wattage: Maximum 6W
- Lumens: 470lm
- Voltage: 240V
- Ingress Protection: IP20 rated
- Operating Temperature: 0 °C to 40 °C
- Lifetime: 50,000hrs (L70/B50)
- Colour: White/black
- Material: Polycarbonate
- Emergency Test/Operation: Manual/non-maintained
- Battery Specification: LiFePO4 battery, 2 cell 6.4V 3200mAh
- Emergency Classification: D80

| PRODUCT CODE | DESCRIPTION                                 | WATTAGE (W) | DIMENSION (MM)                           | MASS (KG) |
|--------------|---|-------------|--|-----------|
| PFLED-RL2    | Pathfinder 2 Recessed White Emergency Light | 6 (max)     | Inner: Ø 75 x H 30 / Outer: Ø 140 x H 30 | 0.3       |
| PFLED-RLBK2  | Pathfinder 2 Recessed Black Emergency Light | 6 (max)     | Inner: Ø 75 x H 30 / Outer: Ø 140 x H 30 | 0.3       |

## ACCESSORY CODE

|                 |                                      |
|-----------------|--------------------------------------|
| DGLCEM3200/2L12 | LiFePO4 battery, 2 cell 6.4V 3200mAh |
| PFSKIT-L2       | Pathfinder 2 Surface Kit White       |
| PFSKIT-LBK2     | Pathfinder 2 Surface Kit Black       |
| FFLEDVK         | Recessed Vandal Kit                  |

| PFLED-RL2, PFLED-RLBK2:<br>AS/NZS 2293.1:2018 CLASSIFICATION TABLE |  |          |      |
|--|--|----------|------|
| ALLOWABLE LUMINAIRE MOUNTING HEIGHT (M)                            | LUMINAIRE MAXIMUM SPACING FOR EACH PLANE (M) |          |      |
|  | C0   | C90/C270 | C180 |
| 2.1  | 11.5   | 11.5     | 11.5 |
| 2.4  | 13.2   | 13.2     | 13.2 |
| 2.7  | 14.8   | 14.8     | 14.8 |
| 3  | 16.5   | 16.5     | 16.5 |
| 3.3  | 18.1   | 18.1     | 18.1 |
| 3.6  | 19.8   | 19.8     | 19.8 |
| 4  | 22   | 22       | 22   |
| 4.5  | 24.7   | 24.7     | 24.7 |
| 5  | 27.5   | 27.5     | 27.5 |
| 6  | 28.9   | 28.8     | 28.9 |
| 7  | 30   | 30       | 30   |
| 8  | 30.9   | 30.9     | 30.9 |
| 9  | 31.5   | 31.5     | 31.5 |
| 10   | 32.1   | 32.1     | 32.1 |
| 15   | 35.5   | 35.5     | 35.5 |
| 20   | 36.9   | 36.9     | 36.9 |

# EMERGENCY CONVERSION KIT

COMPLETE WITH LITHIUM IRON PHOSPHATE BATTERY

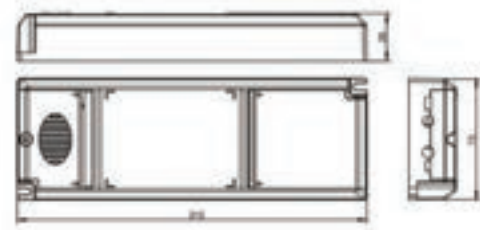
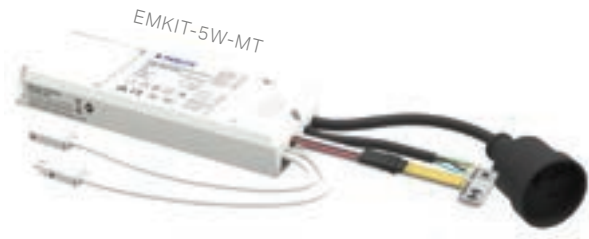

## FEATURES

- Seamless conversion of Pierlite panels and troffers to emergency luminaires
- Integrated emergency solution rather than conventional spitfire emergency solution to save time and cost
- Plug-and-play system allows easy onsite installation
- Unique sticker-based testing configuration avoiding drilling holes in luminaires
- Complete with Lithium Iron Phosphate (LiFePO4) battery
- 3 year warranty, including battery
- All luminaires individually compliant to AS/NZS 2293 standards

## SPECIFICATIONS

- Wattage: Maximum 5W
- Lumens: 634lm
- Voltage: 240V
- Ingress Protection: IP20 rated
- Operating Temperature: 0°C to 50°C
- Colour: White
- Battery Specification: LiFePO4 battery, 4 cell 6.4V 2200mAh
- Emergency Classification: C0/C180:D80 C90/C270: D80

## APPLICATIONS

Ideal for offices and commercial buildings with Pierlite panels and troffers.

ECO PANEL GEN2:  
AS/NZS 2293.1:2018 CLASSIFICATION TABLE

| ALLOWABLE LUMINAIRE MOUNTING HEIGHT (M) | LUMINAIRE MAXIMUM SPACING FOR EACH PLANE (M) |          |      |
|---|--|----------|------|
|   | C0   | C90/C270 | C180 |
| 2.1                                     | 11.5   | 11.5     | 11.5 |
| 2.4                                     | 13.2   | 13.2     | 13.2 |
| 2.7                                     | 14.8   | 14.8     | 14.8 |
| 3                                       | 16.5   | 16.5     | 16.5 |
| 3.3                                     | 18.1   | 18.1     | 18.1 |
| 3.6                                     | 19.8   | 19.8     | 19.8 |
| 4                                       | 22   | 22       | 22   |
| 4.5                                     | 24.7   | 24.7     | 24.7 |
| 5                                       | 27.5   | 27.5     | 27.5 |
| 6                                       | 28.9   | 28.9     | 28.9 |

OCULATED TROFFER:  
AS/NZS 2293.1:2018 CLASSIFICATION TABLE

| ALLOWABLE LUMINAIRE MOUNTING HEIGHT (M) | LUMINAIRE MAXIMUM SPACING FOR EACH PLANE (M) |          |      |
|---|--|----------|------|
|   | C0   | C90/C270 | C180 |
| 2.1                                     | 11.5   | 11.5     | 11.5 |
| 2.4                                     | 13.2   | 13.2     | 13.2 |
| 2.7                                     | 14   | 14.4     | 14   |
| 3                                       | 14.4   | 15.1     | 14.4 |
| 3.3                                     | 14.8   | 15.8     | 14.8 |
| 3.6                                     | 15.1   | 16.5     | 15.1 |
| 4                                       | 15.4   | 17.3     | 15.4 |
| 4.5                                     | 16.3   | 18.3     | 16.3 |
| 5                                       | 17.3   | 19.1     | 17.3 |
| 6                                       | 19.1   | 20.7     | 19.1 |

| PRODUCT CODE | DESCRIPTION   | WATTAGE (W) | DIMENSION (MM)      | MASS (KG) |
|--------------|---|-------------|---------------------|-----------|
| EMKIT-5W-MT  | Emergency conversion module for ECO Panel OcuLED Momentum | 5 (max)     | L 212 x W 73 x H 28 | 0.48      |

# POLO2 OYSTER EMERGENCY LIGHT

COMPLETE WITH LITHIUM IRON PHOSPHATE BATTERY

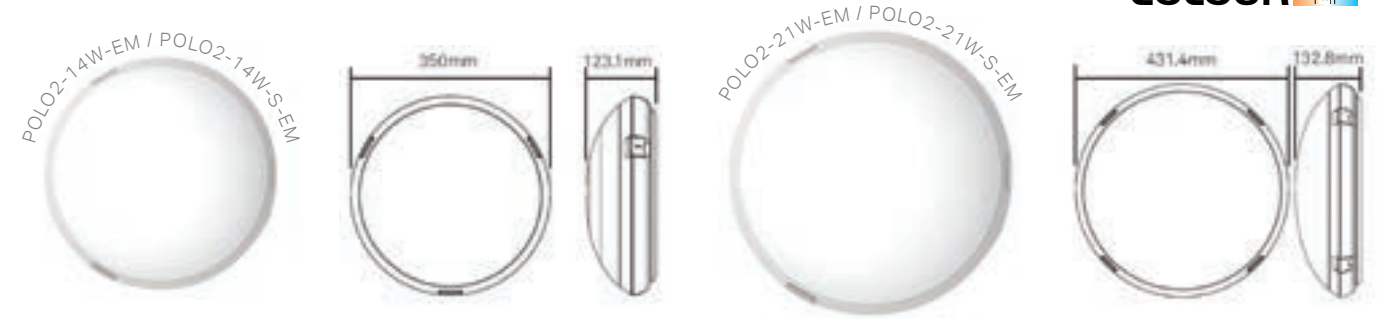

## FEATURES

- Available in two sizes 430mm and 350mm
- Easily change colour temperature between 3000K /4000K/5700K with a switch located inside the diffuser
- Quick fit twist front diffuser with an integral control gear
- IP65 rating to protect unit against dust, insects and water splashes
- Full family available, with standard, emergency and ON/OFF sensor options
- Complete with Lithium Iron Phosphate (LiFePO4) battery
- 3 year warranty including battery
- Compliant to AS/NZS 2293

## SPECIFICATIONS

- Wattage (emergency mode): Maximum 2W
- Lumens (emergency mode):
  - Ø 350 @ 120lm
  - Ø 430 @ 175lm
- Voltage: 240V
- Ingress Protection: IP65 rated
- Operating Temperature: 0°C to 40°C
- Lifetime: 54,000hrs (L70/B50)
- Materials: Polycarbonate
- Colour: White
- Emergency Testing: Manual
- Battery Specification: LiFePO4 battery, 2 cell 6.4V 1500mAh
- Emergency Classification:
  - POLO2 14W: C0/C180: D25 & C90/C270: D25
  - POLO2 21W: C0/C180: D20 & C90/C270: D20

## APPLICATIONS

Ideal solution for surface mounting in residential and commercial spaces.

POLO2-14W-EM, POLO2-14W-S-EM:  
AS/NZS 2293.1:2018 CLASSIFICATION TABLE

| ALLOWABLE LUMINAIRE MOUNTING HEIGHT (M) | LUMINAIRE MAXIMUM SPACING FOR EACH PLANE (M) |          |      |
|---|--|----------|------|
|   | C0   | C90/C270 | C180 |
| 2.1                                     | 11.5   | 11.5     | 11.5 |
| 2.4                                     | 13.2   | 13.2     | 13.2 |
| 2.7                                     | 14.8   | 14.8     | 14.8 |
| 3                                       | 15.7   | 15.7     | 15.7 |
| 3.3                                     | 16.1   | 16.1     | 16.1 |
| 3.6                                     | 16.4   | 16.4     | 16.4 |
| 4                                       | 16.8   | 16.8     | 16.8 |
| 4.5                                     | 17.3   | 17.3     | 17.3 |
| 5                                       | 17.9   | 17.9     | 17.9 |
| 6                                       | 19.2   | 19.2     | 19.2 |
| 7                                       | 20.3   | 20.3     | 20.3 |

POLO2-21W-EM, POLO2-21W-S-EM:  
AS/NZS 2293.1:2018 CLASSIFICATION TABLE

| ALLOWABLE LUMINAIRE MOUNTING HEIGHT (M) | LUMINAIRE MAXIMUM SPACING FOR EACH PLANE (M) |          |      |
|---|--|----------|------|
|   | C0   | C90/C270 | C180 |
| 2.1                                     | 11.5   | 11.5     | 11.5 |
| 2.4                                     | 13.2   | 13.2     | 13.2 |
| 2.7                                     | 14   | 14       | 14   |
| 3                                       | 14.4   | 14.4     | 14.4 |
| 3.3                                     | 14.8   | 14.8     | 14.8 |
| 3.6                                     | 15.1   | 15.1     | 15.1 |
| 4                                       | 15.4   | 15.4     | 15.4 |
| 4.5                                     | 16   | 16       | 16   |
| 5                                       | 16.7   | 16.7     | 16.7 |
| 6                                       | 17.9   | 17.9     | 17.9 |
| 7                                       | 18.8   | 18.8     | 18.8 |

| PRODUCT CODE   | DESCRIPTION                              | WATTAGE (W) AC MODE | LUMENS (LM) AC MODE | DIMENSION (MM) | MASS (KG) |
|----------------|--|---------------------|---------------------|----------------|-----------|
| POLO2-14W-EM   | Polo2 14W Emergency Oyster               | 14                  | 1300                | Ø 350 x H 123  | 1         |
| POLO2-14W-S-EM | Polo2 14W Emergency Oyster ON/OFF Sensor | 14                  | 1300                | Ø 350 x H 123  | 1         |
| POLO2-21W-EM   | Polo2 21W Emergency Oyster               | 21                  | 2000                | Ø 431 x H 133  | 2         |
| POLO2-21W-S-EM | Polo2 21W Emergency Oyster ON/OFF Sensor | 21                  | 2000                | Ø 431 x H 133  | 2         |





STANDARD EMERGENCY  
**LINEAR**

# ECO LED EMERGENCY BATTEN GEN3

COMPLETE WITH LITHIUM IRON PHOSPHATE BATTERY



COLOUR **SELECT** LUMEN **SELECT**

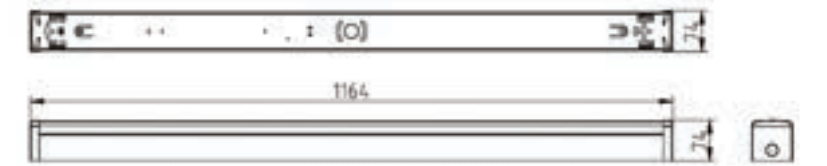

## FEATURES

- Available in multiple wattage and colour options in one fitting
- Increased visual comfort with less than 1% flicker
- Easy installation with a large terminal block, 20mm cable gland and one optional knock-out at the opposite end
- Ceiling or wall mountable steel body, with opal diffuser and Insect proof sealed module
- Complete with Lithium Iron Phosphate (LiFePO4) battery
- 4 year warranty, including Battery
- Compliant to AS/NZS 2293

## APPLICATIONS

General commercial interior lighting.

## SPECIFICATIONS

- Wattage (emergency mode): Maximum 3W
- Lumens (emergency mode): 286lm
- Voltage: 240V
- Ingress Protection: IP20 rated
- Operating Temperature: 0 °C to 40 °C
- Lifetime: 54,000hrs (L70/B50)
- Materials: Polycarbonate
- Colour: White
- Emergency Testing: Manual
- Battery Specification: LiFePO4 battery, 2 cell 6.4V 1500mAh
- Emergency Classification: CO/C180: D32 & C90/C270: D25

**ECOBAT404ECS/ME:  
AS/NZS 2293.1:2018 CLASSIFICATION TABLE**

| ALLOWABLE LUMINAIRE MOUNTING HEIGHT (M) | LUMINAIRE MAXIMUM SPACING FOR EACH PLANE (M) |          |      |
|---|--|----------|------|
|   | C0   | C90/C270 | C180 |
| 2.1                                     | 11.5   | 11.5     | 11.5 |
| 2.4                                     | 13.2   | 13.2     | 13.2 |
| 2.7                                     | 14.8   | 14.8     | 14.8 |
| 3                                       | 16.5   | 15.7     | 16.5 |
| 3.3                                     | 17.6   | 16.1     | 17.6 |
| 3.6                                     | 18   | 16.4     | 18   |
| 4                                       | 18.5   | 16.8     | 18.5 |
| 4.5                                     | 19   | 17.3     | 19   |
| 5                                       | 19.5   | 17.6     | 19.5 |
| 6                                       | 20.1   | 18.1     | 20.1 |
| 7                                       | 20.5   | 18.3     | 20.5 |

| PRODUCT CODE    | DESCRIPTION                   | WATTAGE (W) | LUMENS (LM) | CCT (K) | DIMENSION (MM)       | MASS (KG) |
|-----------------|-------------------------------|-------------|-------------|---------|----------------------|-----------|
|                 |                               | AC MODE     | AC MODE     |         |                      |           |
| ECOBAT404ECS/ME | ECO Emergency LED Batten Gen3 | 36          | 3600        | 4000    | L 1164 x W 74 x H 74 | 1.8       |
|                 |                               | 30          | 3200        | 4000    |                      |           |
|                 |                               | 25          | 2700        | 4000    |                      |           |
|                 |                               | 18          | 2180        | 4000    |                      |           |
|                 |                               | 36          | 4100        | 5000    |                      |           |
|                 |                               | 30          | 3600        | 5000    |                      |           |
|                 |                               | 25          | 2960        | 5000    |                      |           |
|                 |                               | 18          | 2300        | 5000    |                      |           |
|                 |                               | 36          | 3700        | 6500    |                      |           |
|                 |                               | 30          | 3300        | 6500    |                      |           |
|                 |                               | 25          | 2770        | 6500    |                      |           |
|                 |                               | 18          | 2190        | 6500    |                      |           |

# NIPPER LED EMERGENCY BATTEN

COMPLETE WITH LITHIUM IRON PHOSPHATE BATTERY

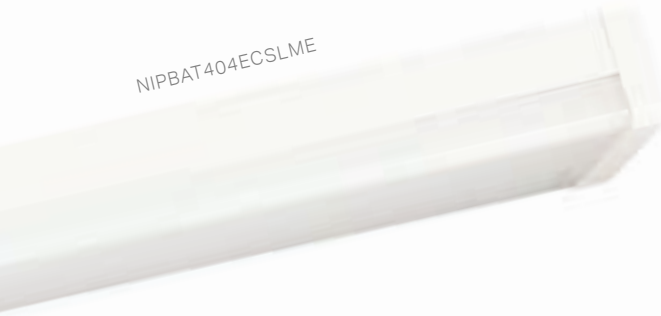

COLOUR SELECT LUMEN SELECT

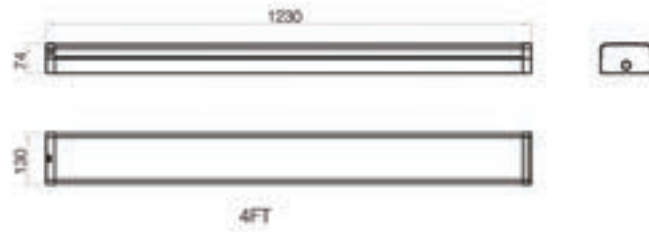

## FEATURES

- Available in multiple wattage and colour options in one fitting
- Wide 130mm body that easily covers footprint of traditional twin fluoro battens with no need for paint work
- Increased visual comfort with less than 1% flicker
- Frosted diffuser is made from impact resistant material that produce clean light, ideal for surface mount or suspended installations
- Large screw-in terminal block inside for quick and easy installation.
- Complete with Lithium Iron Phosphate (LiFePO4) battery
- 4 year warranty, including battery
- Compliant to AS/NZS 2293

## SPECIFICATIONS

- Wattage (emergency mode): Maximum 2.5W
- Lumens (emergency mode): 313lm
- Voltage: 240V
- Ingress Protection: IP20 rated
- Operating Temperature: 0°C to 40°C
- Lifetime: 54,000hrs (L80/B50)
- Materials: Polycarbonate
- Colour: White
- Emergency Test/Operation: Manual/maintained
- Battery Specification: LiFePO4 battery, 2 cell 6.4V 1500mAh
- Emergency Classification: C0/C180 = D40 & C90/C270 = D25

## APPLICATIONS

General commercial and industrial interiors such as factories, warehouses and multi-storey car parks.

NIPBAT404ECSLME: AS/NZS 2293.1:2018 CLASSIFICATION TABLE

| ALLOWABLE LUMINAIRE MOUNTING HEIGHT (M) | LUMINAIRE MAXIMUM SPACING FOR EACH PLANE (M) |          |      |
|---|--|----------|------|
|   | C0   | C90/C270 | C180 |
| 2.1                                     | 11.5   | 11.5     | 11.5 |
| 2.4                                     | 13.2   | 13.2     | 13.2 |
| 2.7                                     | 14.8   | 14.8     | 14.8 |
| 3                                       | 16.5   | 15.7     | 16.5 |
| 3.3                                     | 17.6   | 16.1     | 17.6 |
| 3.6                                     | 18   | 16.4     | 18   |
| 4                                       | 18.5   | 16.8     | 18.5 |
| 4.5                                     | 19   | 17.3     | 19   |
| 5                                       | 19.5   | 17.6     | 19.5 |
| 6                                       | 20.1   | 18.1     | 20.1 |
| 7                                       | 20.5   | 18.3     | 20.5 |

| PRODUCT CODE    | DESCRIPTION                 | WATTAGE (W) AC MODE | LUMENS (LM) AC MODE | CCT (K) | DIMENSION (MM)        | MASS (KG) |
|-----------------|-----------------------------|---------------------|---------------------|---------|-----------------------|-----------|
| NIPBAT404ECSLME | Nipper LED Emergency Batten | 36                  | 3860                | 4000    | L 1230 x W 130 x H 74 | 2.1       |
|                 |                             | 30                  | 3300                | 4000    |                       |           |
|                 |                             | 25                  | 2890                | 4000    |                       |           |
|                 |                             | 18                  | 2200                | 4000    |                       |           |
|                 |                             | 36                  | 4000                | 5000    |                       |           |
|                 |                             | 30                  | 3450                | 5000    |                       |           |
|                 |                             | 25                  | 2990                | 5000    |                       |           |
|                 |                             | 18                  | 2330                | 5000    |                       |           |
|                 |                             | 36                  | 3630                | 6500    |                       |           |
|                 |                             | 30                  | 3160                | 6500    |                       |           |
|                 |                             | 25                  | 2740                | 6500    |                       |           |
|                 |                             | 18                  | 2160                | 6500    |                       |           |

# BWP CONSTRUCTION LED EMERGENCY BATTEN

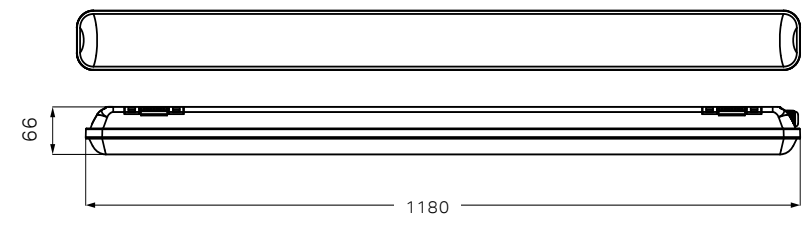
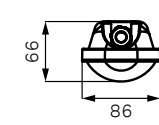

## FEATURES

- Designed to ensure compliance to AS/NZS 3012 – electrical installations on construction sites
- Compliant to 2.67Hz displacement of vibration
- High impact polycarbonate construction
- Includes 2pin 1.7m flex and plug for ease of installation
- Supplied with chain suspension hook or surface mount, for flexible installation
- 1 year warranty, including battery
- Compliant to AS/NZS 2293

## APPLICATIONS

Ideal for temporary lighting in various construction sites such as commercial, high density residential, infrastructure and jobs requiring an economical emergency batten.

BWPCIBS404EM: AS/NZS 2293.1:2018 CLASSIFICATION TABLE

| ALLOWABLE LUMINAIRE MOUNTING HEIGHT (M) | LUMINAIRE MAXIMUM SPACING FOR EACH PLANE (M) |          |      |
|---|--|----------|------|
|   | C0   | C90/C270 | C180 |
| 2.1                                     | 11.5   | 11.5     | 11.5 |
| 2.4                                     | 13.2   | 13.2     | 13.2 |
| 2.7                                     | 14.8   | 14.8     | 14.8 |
| 3                                       | 16.5   | 15.7     | 16.5 |
| 3.3                                     | 18.1   | 16.1     | 18.1 |
| 3.6                                     | 19.5   | 16.4     | 19.5 |
| 4                                       | 20.1   | 16.8     | 20.1 |
| 4.5                                     | 20.7   | 17.3     | 20.7 |
| 5                                       | 21.2   | 17.6     | 21.2 |
| 6                                       | 22.1   | 18.1     | 22.1 |
| 7                                       | 22.6   | 18.3     | 22.6 |
| 8                                       | 23   | 18.2     | 23   |
| 9                                       | 23.1   | 17.8     | 23.1 |
| 10                                      | 23   | 17.2     | 23   |

## SPECIFICATIONS

- Wattage (emergency mode): Maximum 3W
- Lumens (emergency mode): 303lm
- Voltage: 240V
- Ingress Protection: IP65 rated
- Impact Rating: IK09
- Operating Temperature: 0°C to 40°C
- Lifetime: 36,000hrs (L70/B50)
- Materials: Polycarbonate
- Colour: Grey
- Emergency Test/Operation: Manual/maintained
- Battery Specification: NiCd battery, 6 cell 1.2V 1500mAh
- Emergency Classification:
  - AS/NZS 2293: C0/C180:D40 & C90/C270:D25
  - AS/NZS 3012: C0/C180:C80 & C90/C270:C80

BWPCIBS404EM: AS/NZS 2293.1:2018 CLASSIFICATION TABLE

| ALLOWABLE LUMINAIRE MOUNTING HEIGHT (M) | LUMINAIRE MAXIMUM SPACING FOR EACH PLANE (M) |          |      |
|---|--|----------|------|
|   | C0   | C90/C270 | C180 |
| 2.1                                     | 5.9  | 5.9      | 5.9  |
| 2.4                                     | 6.2  | 6.2      | 6.2  |
| 2.7                                     | 6.4  | 6.4      | 6.4  |
| 3                                       | 6.5  | 6.5      | 6.5  |
| 3.3                                     | 6.6  | 6.6      | 6.6  |
| 3.6                                     | 6.7  | 6.7      | 6.7  |
| 4                                       | 6.7  | 6.7      | 6.7  |
| 4.5                                     | 6.6  | 6.6      | 6.6  |
| 5                                       | 6.3  | 6.3      | 6.3  |

| PRODUCT CODE | DESCRIPTION                                      | WATTAGE (W) AC MODE | LUMENS (LM) AC MODE | DIMENSION (MM)      | MASS (KG) |
|--------------|--|---------------------|---------------------|---------------------|-----------|
| BWPCONS404EM | BWP Construction Emergency Batten 40W Maintained | 40                  | 3419                | L 1180 x H 66 x W86 | 1.8       |



# BWP ECO LED EMERGENCY WEATHERPROOF BATTEN



COMPLETE WITH LITHIUM IRON PHOSPHATE BATTERY

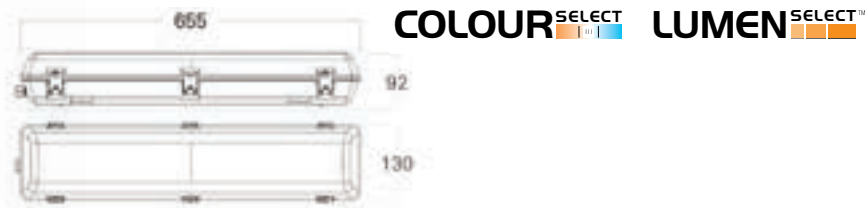

## FEATURES

- Available in multiple size, wattage and colour options
- Wide 130mm body that easily covers footprint of traditional twin fluoro battens with no need for paint work
- Easy installation with a large terminal block, stainless steel mounting clips, 20mm cable gland and one optional knock-out at the opposite end
- Protection against moisture and dust with an IP65 rating
- Available in sensor version with occupancy detection and daylight harvesting
- Complete with Lithium Iron Phosphate (LiFePO4) battery
- 3 year warranty, including battery
- Compliant to AS/NZS 2293

## SPECIFICATIONS

- Wattage (emergency mode): Maximum 3W
- Lumens (emergency mode):
  - 2FT @ 314lm
  - 4FT @ 327lm
  - 5FT @ 264lm
- Voltage: 240V
- Ingress Protection: IP65 rated
- Impact Rating: IK08
- Operating Temperature: 0°C to 40°C
- Lifetime: 54,000hrs (L70/B50)
- Materials: Polycarbonate
- Colour: Grey
- Emergency Test/Operation: Manual/maintained
- Battery Specification: LiFePO4 battery, 2 cell 6.4V 1500mAh
- Emergency Classification:
  - BWPECO202ECSEM: CO/C180: D50 & C90/C270: D25
  - BWPECO404ECSEM: CO/C180: D50 & C90/C270: D32
  - BWPECO505ECSEM: CO/C180: D32 & C90/C270: D32
  - BWPECO404ECSEMS: CO/C180: D80 & C90/C270: D40

## APPLICATIONS

Suitable for industrial environments that require protection against moisture and dust.

**BWPECO202ECSEM:**  
AS/NZS 2293.1:2018 CLASSIFICATION TABLE

| ALLOWABLE LUMINAIRE MOUNTING HEIGHT (M) | LUMINAIRE MAXIMUM SPACING FOR EACH PLANE (M) |          |      |
|---|--|----------|------|
|   | C0   | C90/C270 | C180 |
| 2.1                                     | 11.5   | 11.5     | 11.5 |
| 2.4                                     | 13.2   | 13.2     | 13.2 |
| 2.7                                     | 14.8   | 14.8     | 14.8 |
| 3                                       | 16.5   | 15.7     | 16.5 |
| 3.3                                     | 18.1   | 16.1     | 18.1 |
| 3.6                                     | 19.8   | 16.4     | 19.8 |
| 4                                       | 21.8   | 16.8     | 21.8 |
| 4.5                                     | 22.5   | 17.3     | 22.5 |
| 5                                       | 23.1   | 17.6     | 23.1 |
| 6                                       | 24.1   | 18.1     | 24.1 |
| 7                                       | 24.9   | 18.3     | 24.9 |

**BWPECO404ECSEM:**  
AS/NZS 2293.1:2018 CLASSIFICATION TABLE

| ALLOWABLE LUMINAIRE MOUNTING HEIGHT (M) | LUMINAIRE MAXIMUM SPACING FOR EACH PLANE (M) |          |      |
|---|--|----------|------|
|   | C0   | C90/C270 | C180 |
| 2.1                                     | 11.5   | 11.5     | 11.5 |
| 2.4                                     | 13.2   | 13.2     | 13.2 |
| 2.7                                     | 14.8   | 14.8     | 14.8 |
| 3                                       | 16.5   | 16.5     | 16.5 |
| 3.3                                     | 18.1   | 17.6     | 18.1 |
| 3.6                                     | 19.8   | 18       | 19.8 |
| 4                                       | 21.8   | 18.5     | 21.8 |
| 4.5                                     | 22.5   | 19       | 22.5 |
| 5                                       | 23.1   | 19.5     | 23.1 |
| 6                                       | 24.1   | 20.1     | 24.1 |
| 7                                       | 24.9   | 20.5     | 24.9 |

**BWPECO505ECSEM:**  
AS/NZS 2293.1:2018 CLASSIFICATION TABLE

| ALLOWABLE LUMINAIRE MOUNTING HEIGHT (M) | LUMINAIRE MAXIMUM SPACING FOR EACH PLANE (M) |          |      |
|---|--|----------|------|
|   | C0   | C90/C270 | C180 |
| 2.1                                     | 11.5   | 11.5     | 11.5 |
| 2.4                                     | 13.2   | 13.2     | 13.2 |
| 2.7                                     | 14.8   | 14.8     | 14.8 |
| 3                                       | 16.5   | 16.5     | 16.5 |
| 3.3                                     | 17.6   | 17.6     | 17.6 |
| 3.6                                     | 18   | 18       | 18   |
| 4                                       | 18.5   | 18.5     | 18.5 |
| 4.5                                     | 19   | 19       | 19   |
| 5                                       | 19.5   | 19.5     | 19.5 |
| 6                                       | 20.1   | 20.1     | 20.1 |
| 7                                       | 20.5   | 20.5     | 20.5 |

**BWPECO404ECSEMS:**  
AS/NZS 2293.1:2018 CLASSIFICATION TABLE

| ALLOWABLE LUMINAIRE MOUNTING HEIGHT (M) | LUMINAIRE MAXIMUM SPACING FOR EACH PLANE (M) |          |      |
|---|--|----------|------|
|   | C0   | C90/C270 | C180 |
| 2.1                                     | 11.5   | 11.5     | 11.5 |
| 2.4                                     | 13.2   | 13.2     | 13.2 |
| 2.7                                     | 14.8   | 14.8     | 14.8 |
| 3                                       | 16.5   | 16.5     | 16.5 |
| 3.3                                     | 18.1   | 18.1     | 18.1 |
| 3.6                                     | 19.8   | 19.7     | 19.8 |
| 4                                       | 22   | 20.8     | 22   |
| 4.5                                     | 24.7   | 22       | 24.7 |
| 5                                       | 27.5   | 23.1     | 27.5 |
| 6                                       | 28.9   | 25.2     | 28.9 |
| 7                                       | 30   | 27       | 30   |

| PRODUCT CODE    | DESCRIPTION                       | WATTAGE (W) AC MODE | LUMENS (LM) AC MODE  | CCT (K)              | DIMENSION (MM)        | MASS (KG) |
|-----------------|-----------------------------------|---------------------|----------------------|----------------------|-----------------------|-----------|
| BWPECO202ECSEM  | BWP ECO Batten G2 2FT             | 20                  | 2100<br>2500<br>2100 | 3000<br>4000<br>6000 | L 655 x W 130 x H 92  | 1.46      |
|                 |                                   | 40                  | 4700                 | 3000                 |                       |           |
|                 |                                   | 33                  | 4000                 | 3000                 |                       |           |
| BWPECO404ECSEM  | BWP ECO Batten G2 4FT             | 40                  | 5200                 | 4000                 | L 1265 x W 130 x H 92 | 2.70      |
|                 |                                   | 27                  | 3600                 | 4000                 |                       |           |
|                 |                                   | 20                  | 2500                 | 6000                 |                       |           |
| BWPECO404ECSEMS | BWP Eco Batten G2 4FT with Sensor | 44                  | 4575<br>5065<br>4942 | 3000<br>4000<br>6000 | L 1265 x W 130 x H 92 | 2.82      |
| BWPECO505ECSEM  | BWP ECO Batten G2 5FT             | 52                  | 5900<br>6200<br>5700 | 3000<br>4000<br>6000 | L 1565 x W 130 x H 92 | 3         |



STANDARD EMERGENCY

# BULKHEADS

## DECO LED EMERGENCY BULKHEAD

COMPLETE WITH LITHIUM IRON PHOSPHATE BATTERY



### FEATURES

- Architectural low profile design, with a durable die-cast aluminium body and robust polycarbonate opal diffuser
- Available in white and black, with a quick and simple installation
- Easily change between standard mode and photocell/daylight harvesting sensor mode with an internal switch
- Complete with Lithium Iron Phosphate (LiFeP04) battery
- 3 year luminaire warranty and 1 year battery warranty
- Compliant to AS/NZS 2293

### SPECIFICATIONS

- Wattage (emergency mode): Maximum 3W
- Lumens (emergency mode): 311lm
- Voltage: 240V
- Ingress Protection: IP65 rated
- Operating Temperature: 0°C to 40°C
- Lifetime: 36,000hrs (L70/B50)
- Colour Temperature: 5000K
- Colour: White/Black
- Material: Aluminium body and polycarbonate diffuser
- Emergency Test/Operation: Manual/maintained
- Battery Specification: Ni-Cad battery, 4 cell 4.8V 2500mAh

### APPLICATIONS

Ideal for commercial, domestic and architectural lighting.

| PRODUCT CODE | DESCRIPTION                         | WATTAGE (W) | DIMENSION (MM)       | MASS (KG) |
|--------------|-------------------------------------|-------------|----------------------|-----------|
| DECOLEDMS-BK | Deco LED Emergency C/W Sensor Black | 13          | L 265 x W 160 x H 98 | 1.6       |
| DECOLEDMS-W  | Deco LED Emergency C/W Sensor White | 13          | L 265 x W 160 x H 98 | 1.6       |





# DALI EMERGENCY

## DALI HAS BECOME THE GLOBAL STANDARD PROTOCOL FOR LIGHTING CONTROL

DALI components make it possible to create a flexible, cost-effective and decentralised lighting system. DALI deals only with lighting system components. This limitation is not a disadvantage; it simplifies planning and installation.

DALI is simpler than building management systems and less expensive. Interfaces and converters can combine DALI components with any building management system; DALI can function as a stand-alone system or as a subsystem.



## PIERLITE DALI LED EMERGENCY DRIVER

The optimised LED driver to complete your Pierlite emergency solution.

The high performance DALI Emergency LED driver designed to drive a designated emergency lighting LED or array when the normal mains AC power has failed.



**DALI COMPLIANT**  
All DALI features are fully supported and officially compliant.



**BATTERY DETECTION**  
Automatically detects and re-configures itself to suit available battery.



**RATED DURATION**  
Different durations can be pre-set at the factory for local standards.  
Example - 1 hour, 2 hours, 3 hours, 4 hours or greater.

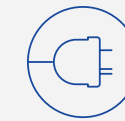

**SINGLE PLUG**  
One single battery plug ensures simpler installation.



**NO JUMPERS**  
Automatically detects operating conditions.

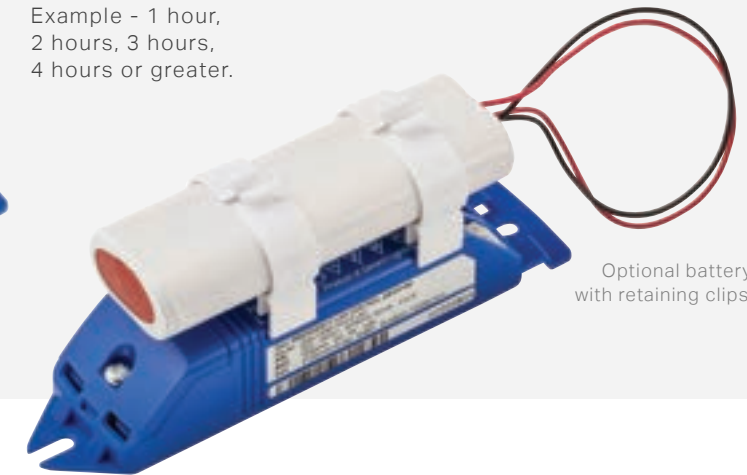

Optional battery pack with retaining clips



Xi extended intelligence "chip" inside

**LED DRIVER CAPABILITIES**  
Logging data on vital battery operating statistics. Logging data on vital unit operating statistics. In-service firmware upgradeable. Automated fault notification.

**FACTORY CONFIGURATION**  
LED drivers can be configured to suit any of the compatible battery types with a specific rated duration time to suit local regulations.

**COMPATIBLE BATTERIES**  
NiMH: Nickel Metal Hydride  
NiCd: Nickel Cadmium  
LiFePO4: Lithium Ferro Phosphate



Discover the Xi advantage, a new layer of DALI extended intelligence.

Pierlite's Xi-extended intelligence is the next generation layer of digital intelligence. It provides advanced features and functionality for both hardware and software.





SELF TEST / DALI EMERGENCY

# EXIT SIGNS

## WEATHERLUX EXIT LIGHT GEN2

COMPLETE WITH LITHIUM IRON PHOSPHATE BATTERY

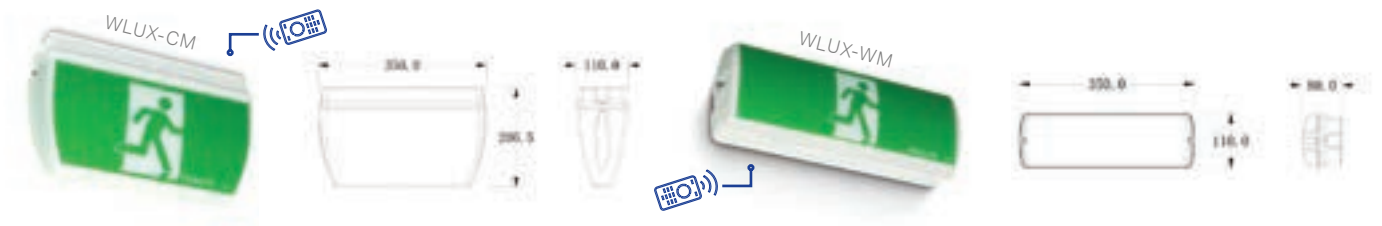

### FEATURES

- Save time and money while ensuring accuracy with integrated NFC functionality, allowing short addresses to be assigned without powering the exit light
- Durable white IP65 polycarbonate body, available for ceiling or wall mounting
- Self-test if not connected to DALI network, with health status reported by bicolour LED indicator
- One-box solution with all pictogram inserts and diffuser included
- Designed for 16m (wall mount) and 24m (ceiling mount) viewing distance
- Complete with Lithium Iron Phosphate (LiFePO4) battery
- 4 year warranty, including battery
- Compliant to AS/NZS 2293

### SPECIFICATIONS

- Wattage: Maximum 5W
- Lumens:
  - Ceiling Mount: 97lm @ 2.2W
  - Wall Mount: 72lm @ 2.2W
- Voltage: 240V
- Ingress Protection: IP65 rated
- Impact Rating: IK08
- Operating Temperature: 0°C to 50°C
- Lifetime: 50,000hrs (L70/B50)
- Colour: White
- Emergency Test/Operation: Self test/DALI/maintained
- Battery Specification: LiFePO4 battery, 1 cell 3.2V 3200mAh
- Emergency Classification:
  - WLUX-CM: CO/C180 D10 & C90/C270:D10
  - WLUX-WM: CO/C180 D08 & C90/C270:D10

### APPLICATIONS

Suitable for damp environments and areas such as warehouses, production facilities, car parks and schools.

**WLUX-CM:**  
AS/NZS 2293.1:2018 CLASSIFICATION TABLE

| ALLOWABLE LUMINAIRE MOUNTING HEIGHT (M) | LUMINAIRE MAXIMUM SPACING FOR EACH PLANE (M) |          |      |
|---|--|----------|------|
|   | C0   | C90/C270 | C180 |
| 2.1                                     | 10.2   | 10.2     | 10.2 |
| 2.4                                     | 10.5   | 10.5     | 10.5 |
| 2.7                                     | 10.8   | 10.8     | 10.8 |

**WLUX-WM:**  
AS/NZS 2293.1:2018 CLASSIFICATION TABLE

| ALLOWABLE LUMINAIRE MOUNTING HEIGHT (M) | LUMINAIRE MAXIMUM SPACING FOR EACH PLANE (M) |          |
|---|--|----------|
|   | C0   | C90/C270 |
| 2.1                                     | 9.4  | 10.2     |
| 2.4                                     | 9.7  | 10.5     |
| 2.7                                     | 9.9  | 10.8     |

| PRODUCT CODE | DESCRIPTION                     | WATTAGE (W) | DIMENSION (MM)          | MASS (KG) |
|--------------|---------------------------------|-------------|-------------------------|-----------|
| WLUX-CM      | Weatherlux 2 Exit Ceiling Mount | 5 (max)     | L 350 x W 110 x H 206.5 | 2.3       |
| WLUX-WM      | Weatherlux 2 Exit Wall Mount    | 5 (max)     | L 350 x W 110 x H 80    | 1.2       |

SELF TEST / DALI EMERGENCY EXIT SIGNS



# BLADE 2 DALI LED EXIT LIGHT

COMPLETE WITH LITHIUM IRON PHOSPHATE BATTERY

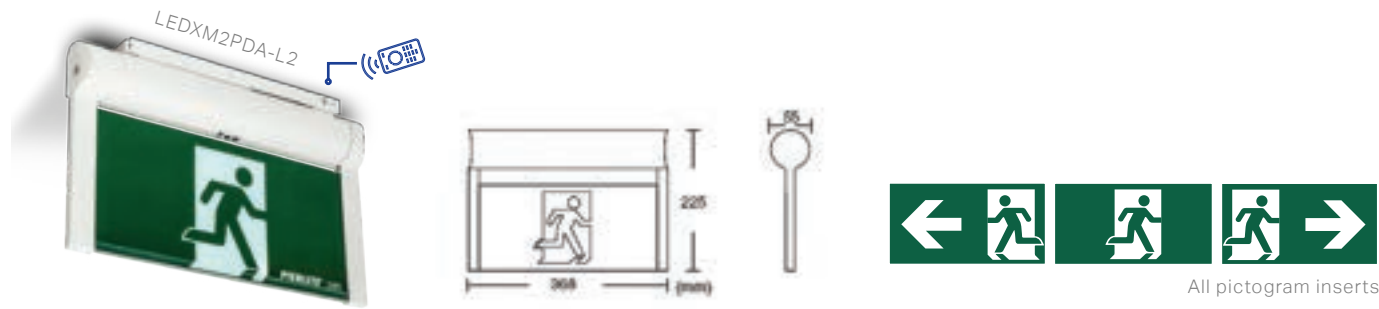

## FEATURES

- Save time and money while ensuring accuracy with integrated NFC functionality, allowing short addresses to be assigned without powering the exit light
- Ceiling mount, with optional wall mount, suspension and recessed kit
- Optional IP65 enclosure (Aqualock)
- Self-test if not connected to DALI network, with health status reported by bicolour LED indicator
- One-box solution including all pictogram inserts
- 24m viewing distance
- Complete with replaceable Lithium Iron Phosphate (LiFePO4) battery
- 4 year warranty, including battery
- Compliant to AS/NZS 2293

## APPLICATIONS

Designed for applications where aesthetics are everything, this premium exit sign is suitable for commercial office areas, hotels, shopping complexes, apartments and hospitals.

## OPTIONAL ACCESSORIES

IP65 enclosure, recessed kit, suspension kit and cantilever bracket wall mount kit.

## SPECIFICATIONS

- Wattage: Maximum 4.6W
- Lumens: 31lm @ 0.9W
- Voltage: 240V
- Ingress Protection: IP20 rated and optional IP65 kit
- Operating Temperature: 0°C to 40°C
- Lifetime: 54,000hrs (L70/B50)
- Colour: White
- Emergency Test/Operation: Self test/DALI/maintained
- Material: Acrylic
- Battery Specification: LiFePO4 battery, 1 cell 3.2V 3200mAh
- Emergency Classification: C0/C180:D5 & C90/C270: D5

LEDXM2PDA-L2:  
AS/NZS 2293.1:2018 CLASSIFICATION TABLE

| ALLOWABLE LUMINAIRE MOUNTING HEIGHT (M) | LUMINAIRE MAXIMUM SPACING FOR EACH PLANE (M) |          |      |
|---|--|----------|------|
|   | C0   | C90/C270 | C180 |
| 2.1                                     | 7.8  | 7.8      | 7.8  |
| 2.4                                     | 8  | 8        | 8    |
| 2.7                                     | 8.1  | 8.1      | 8.1  |
| 3                                       | 8.2  | 8.2      | 8.2  |
| 3.3                                     | 8.2  | 8.2      | 8.2  |
| 3.6                                     | 8.1  | 8.1      | 8.1  |
| 4                                       | 8.2  | 8.2      | 8.2  |
| 4.5                                     | 8.2  | 8.2      | 8.2  |

| PRODUCT CODE | DESCRIPTION                    | WATTAGE (W) | DIMENSION (MM)       | MASS (KG) |
|--------------|--------------------------------|-------------|----------------------|-----------|
| LEDXM2PDA-L2 | Blade 2 DALI with NFC Function | 4.6 (max)   | L 368 x W 55 x H 225 | 0.9       |

### ACCESSORY CODE

|                 |                                      |
|-----------------|--------------------------------------|
| DGLCEM3200/1L11 | LiFePO4 battery, 1 cell 3.2V 3200mAh |
| AQUALOCK-W      | IP65 Enclosure                       |
| LEDRB           | Recessed Bracket Kit White           |
| SKITLED         | Suspension Kit                       |
| EXCB            | Cantilever Bracket Wall Mount Kit    |

# STINGRAY 2 DALI LED EXIT LIGHT

COMPLETE WITH LITHIUM IRON PHOSPHATE BATTERY

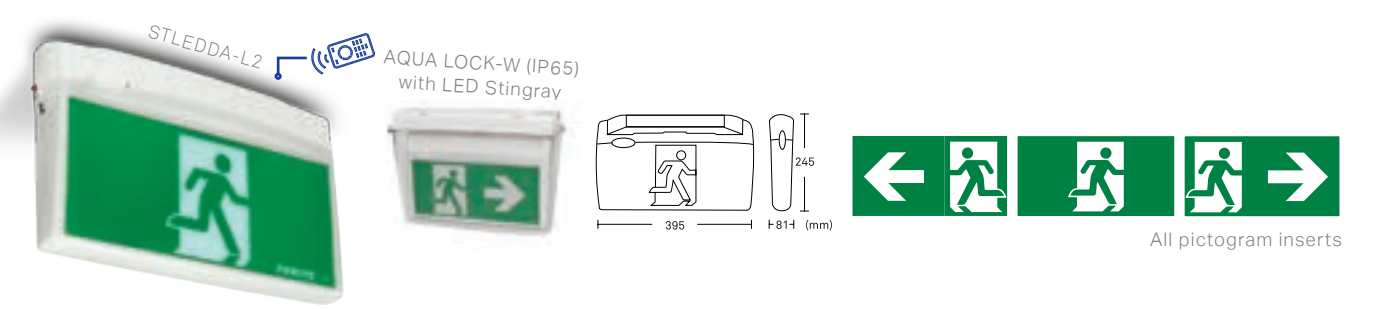

## FEATURES

- Save time and money while ensuring accuracy with integrated NFC functionality, allowing short addresses to be assigned without powering the exit light
- Ceiling mount, with optional wall mount kit
- Self-test if not connected to DALI network, with health status reported by bicolour LED indicator
- One-box solution including all pictogram inserts
- Optional IP65 enclosure (Aqualock)
- 24m viewing distance
- Complete with replaceable Lithium Iron Phosphate (LiFePO4) battery
- 4 year warranty including battery
- Compliant to AS/NZS 22933

## SPECIFICATIONS

- Wattage: Maximum 4.6W
- Lumens: 27lm @ 1W
- Voltage: 240V
- Ingress Protection: IP20 rated and optional IP65 kit
- Operating Temperature: 0°C to 40°C
- Lifetime: 50,000hrs (L70/B50)
- Colour: White
- Emergency Test/Operation: Self test/DALI/maintained
- Battery Specification: LiFePO4 battery, 1 cell 3.2V 3200mAh
- Emergency Classification: C0/C180:E3.2 & C90/C270:D4

## APPLICATIONS

Ideal for commercial and apartment buildings, retail complexes and halls.

## OPTIONAL ACCESSORIES

IP65 enclosure and cantilever bracket wall mount kit.

STLEDDA-L2:  
AS/NZS 2293.1:2018 CLASSIFICATION TABLE

| ALLOWABLE LUMINAIRE MOUNTING HEIGHT (M) | LUMINAIRE MAXIMUM SPACING FOR EACH PLANE (M) |          |
|---|--|----------|
|   | C0/C180                                      | C90/C270 |
| 2.1                                     | 5.8  | 7.1      |
| 2.4                                     | 6.1  | 7.2      |
| 2.7                                     | 6.4  | 7.3      |

| PRODUCT CODE | DESCRIPTION                       | WATTAGE (W) | DIMENSION (MM)       | MASS (KG) |
|--------------|-----------------------------------|-------------|----------------------|-----------|
| STLEDDA-L2   | Stingray 2 DALI with NFC Function | 4.6 (max)   | L 395 x W 81 x H 245 | 1.2       |

### ACCESSORY CODE

|                 |                                       |
|-----------------|---------------------------------------|
| DGLCEM3200/1L11 | LiFePO4 Battery, 1 Cell 3.2V 3200 mAh |
| AQUALOCK-W      | IP65 Enclosure                        |
| EXCB            | Cantilever Bracket Wall Mount Kit     |

# WARDEN 2 DALI LED EXIT LIGHT

COMPLETE WITH LITHIUM IRON PHOSPHATE BATTERY



Selection of product codes available,



## FEATURES

- Robust vandal resistant casing for areas requiring an impact and tamper proof option
- Ceiling or wall mountable with a slimline, aesthetic and practical design
- One-box solution including all pictogram inserts
- Self-test if not connected to DALI network, with health status reported by bicolour LED indicator
- 32m viewing distance
- Complete with replaceable Lithium Iron Phosphate (LiFePO4) battery, in 2hr or 4hr versions
- 4 years warranty including battery
- Compliant to AS/NZS 2293

## APPLICATIONS

Ideal for use in public housing, schools, psychiatric wards, military barracks, car parks, parks, hospitals, train stations and public areas.

## OPTIONAL ACCESSORIES

Torx security screws.

## SPECIFICATIONS

- Wattage: Maximum 6.1W
- Lumens: 57lm @ 2W
- Voltage: 240V
- Ingress Protection: IP65
- Impact Rating: IK10
- Operating Temperature: 0°C to 40°C
- Lifetime: 54,000hrs (L70/B50)
- Construction material: Robust polycarbonate body, UV stabilised clear polycarbonate lens
- Battery Specification: Rechargeable battery pack
  - 4 hour: LiFePO4 2Cell 6.4V 3200mAh
  - 2 hour: LiFePO4 2Cell 6.4V 1500mAh

| PRODUCT CODE   | DESCRIPTION   | WATTAGE (W) | DURATION (HRS) | DIMENSION (MM)        | MASS (KG) |
|----------------|---|-------------|----------------|-----------------------|-----------|
| WADLEDDSDA-L4H | Warden 2 32M DALI Double Sided 4 Hour Battery Back Up | 5.8 (max)   | 4              | L 420 x W 105 x H 230 | 2.8       |
| WADLEDSSDA-L4H | Warden 2 32M DALI Single Sided 4 Hour Battery Back Up | 6.1 (max)   | 4              | L 420 x W 105 x H 230 | 2.8       |
| WADLEDDSDA-L   | Warden 2 32M DALI Double Sided 2 Hour Battery Back Up | 5.8 (max)   | 2              | L 420 x W 105 x H 230 | 2.8       |
| WADLEDSSDA-L   | Warden 2 32M DALI Single Sided 2 Hour Battery Back Up | 6.1 (max)   | 2              | L 420 x W 105 x H 230 | 2.8       |

| ACCESSORY CODE  | DESCRIPTION   |
|-----------------|---|
| DGLCEM3200/2L12 | LiFePO4 2Cell 6.4V 3200mAh (only WADLEDDSDA-L4H or WADLEDSSDA-L4H)                                    |
| DGLCEM1500/2L21 | LiFePO4 2Cell 6.4V 1500mAh (only WADLEDDSDA-L or WADLEDSSDA-L)  |
| 97002448        | Single Torx screw (4 torx screws required for single sided) (8 torx screws required for double sided) |

# JUMBO 2 DALI LED EXIT LIGHT

COMPLETE WITH LITHIUM IRON PHOSPHATE BATTERY

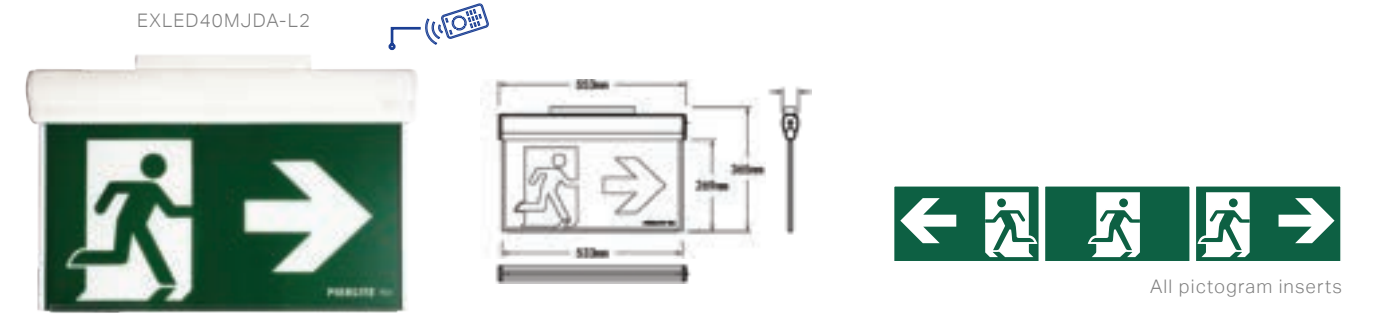

## FEATURES

- Save time and money while ensuring accuracy with integrated NFC functionality, allowing short addresses to be assigned without powering the exit light
- Ceiling or wall mountable for flexibility
- One-box solution, including all pictogram inserts
- 40m viewing distance
- Self-test if not connected to DALI network, with health status reported by bicolour LED indicator
- Complete with replaceable Lithium Iron Phosphate (LiFePO4) battery
- 4 years warranty including battery
- Compliant to AS/NZS 2293

## APPLICATIONS

Ideal for large open areas where aesthetics are important - commercial buildings, airports, hotels, retail, apartments and hospitals.

## SPECIFICATIONS

- Wattage: Maximum 7.5W
- Lumens: 75lm @ 7.5W
- Voltage: 240V
- Ingress Protection: IP20 rated
- Operating Temperature: 0°C to 40°C
- Lifetime: 50,000hrs (L70/B50)
- Colour: White
- Emergency Test/Operation: Self test/ DALI/ maintained
- Battery Specification: LiFePO4 battery, 1 cell 3.2V 3200mAh
- Emergency Classification: C0/C180:D8 & C90/C270:C12.5

### EXLED40MJDA-L2: AS/NZS 2293.1:2018 CLASSIFICATION TABLE

| ALLOWABLE LUMINAIRE MOUNTING HEIGHT (M) | LUMINAIRE MAXIMUM SPACING FOR EACH PLANE (M) |          |      |
|---|--|----------|------|
|   | C0   | C90/C270 | C180 |
| 2.1                                     | 9.4  | 7.8      | 9.4  |
| 2.4                                     | 9.7  | 8.2      | 9.7  |
| 2.7                                     | 9.9  | 8.6      | 9.9  |
| 3                                       | 10.1   | 8.9      | 10.1 |
| 3.3                                     | 10.2   | 9.2      | 10.2 |
| 3.6                                     | 10.3   | 9.5      | 10.3 |

| PRODUCT CODE   | DESCRIPTION                 | WATTAGE (W) | DIMENSION (MM)       | MASS (KG) |
|----------------|-----------------------------|-------------|----------------------|-----------|
| EXLED40MJDA-L2 | Jumbo 2 DALI 40M Exit Light | 6 (max)     | L 533 x H 365 x W 46 | 2         |

| ACCESSORY CODE  | DESCRIPTION                          |
|-----------------|--------------------------------------|
| DGLCEM3200/1L11 | LiFePO4 Battery, 1 Cell 3.2V 3200mAh |



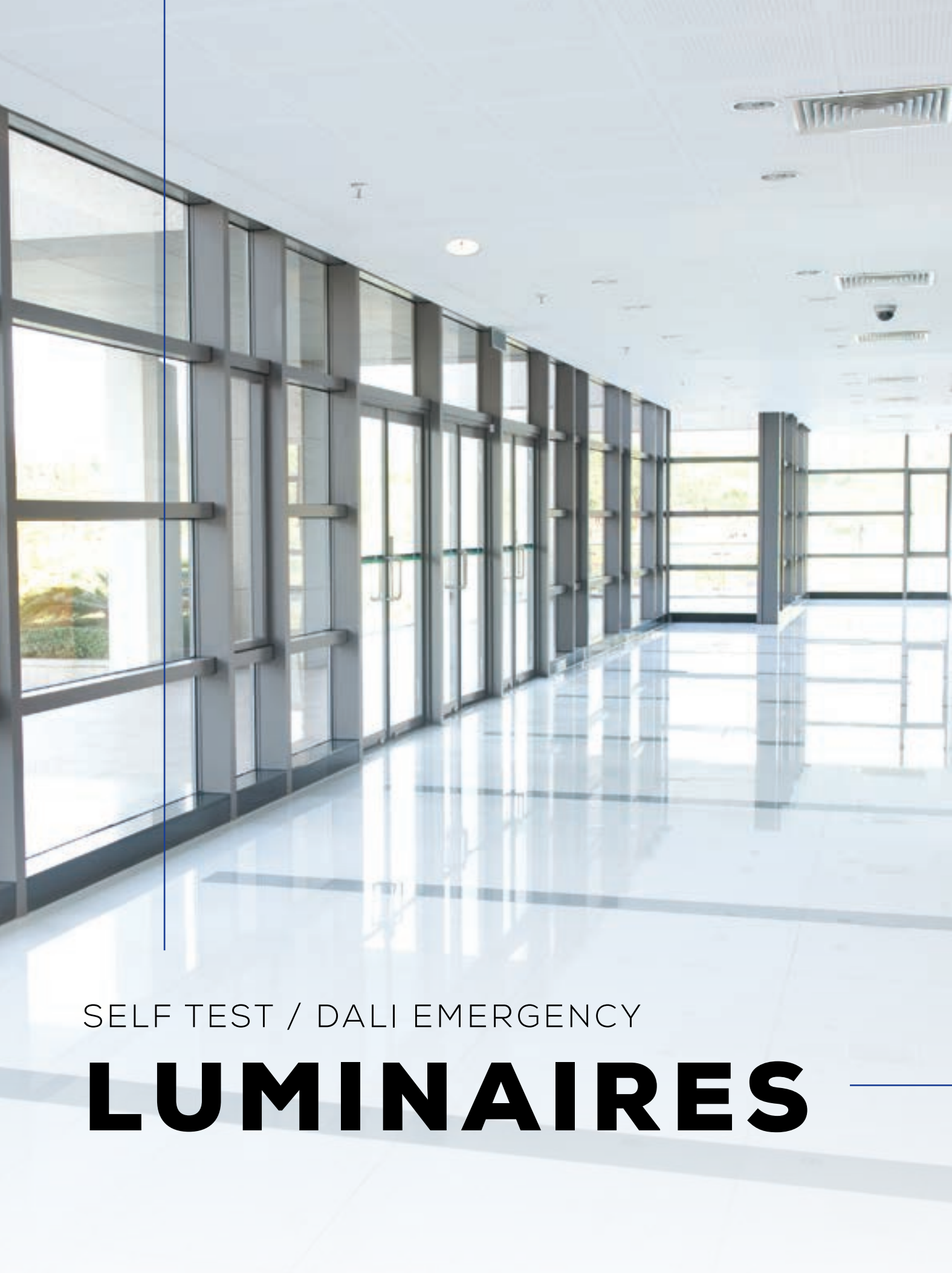

SELF TEST / DALI EMERGENCY

# LUMINAIRES

## GUARDIAN 2 DALI LED EMERGENCY FLOODLIGHT

COMPLETE WITH LITHIUM IRON PHOSPHATE BATTERY



### FEATURES

- Adjustable twin head floodlight for wall or ceiling surface mounting
- Non corrosive polycarbonate housing and reflectors
- Self-test if not connected to DALI network with health status reported by bicolour LED indicator
- Standard version also available
- Complete with replaceable Lithium Iron Phosphate (LiFePO4) battery
- 4 year warranty including battery
- Compliant to AS/NZS 2293

### APPLICATIONS

Ideal for interior commercial/ industrial spaces, retail stores, public auditoriums, warehouse facilities, factories, airports and school halls.

### OPTIONAL ACCESSORIES

IP65 enclosure.

### SPECIFICATIONS

- Wattage: Maximum 4W
- Lumens: 228lm per head (total 456lm)
- Voltage: 240V
- Ingress Protection: IP20 rated with optional IP65 enclosure
- Lifetime: 50,000hrs (L70/B50)
- Operating Temperature: 0°C to 40°C
- Material: Polycarbonate housing and reflector
- Colour: White
- Emergency Test/Operation: Self test/DALI/non-maintained
- Battery Specification: LiFePO4 battery, 2 cell 6.4V 3200mAh

| PRODUCT CODE | DESCRIPTION                              | WATTAGE (W) | LUMENS (LM)                  | DIMENSION (MM)      | MASS (KG) |
|--------------|--|-------------|------------------------------|---------------------|-----------|
| GRLED7FL-L2  | Non-maintained DALI Emergency Floodlight | 4 (max)     | 228lm per head (total 456lm) | L 350 x W 80 x H 80 | 1         |

### ACCESSORY CODE

|                 |                                      |
|-----------------|--------------------------------------|
| GRWPENCL        | IP65 enclosure                       |
| DGLCEM3200/2L12 | LiFePO4 battery, 2 cell 6.4V 3200mAh |

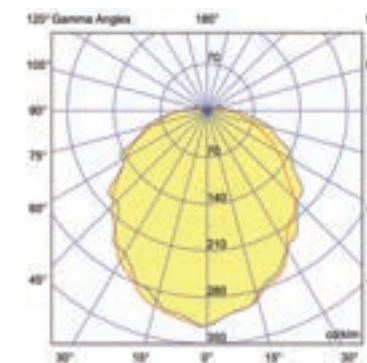

### POLAR GRAPH

1. Represents only one LED adjustable head and the true lumens will result in 2 times 228lm (total lumens: 456lm)
2. Emergency flood units cannot be issued with an AS/NZS 2293.1:2018.3 spacing table classification as they have adjustable heads (not fixed).
3. Specifiers note: IES files are available for lighting design calculations.

# PATHFINDER ECO DALI LED EMERGENCY LIGHT



COMPLETE WITH LITHIUM IRON PHOSPHATE BATTERY



## FEATURES

- High luminous efficacy to maximise spacing
- Available in recessed or ceiling surface mount
- Flex and plug included for easy installation
- Self-test if not connected to DALI network with health status reported by bicolour LED indicator
- Standard version also available
- Complete with Lithium Iron Phosphate (LiFePO4) battery
- 4 year warranty, including battery
- Compliant to AS/NZS 2293

PFDLED-ECO, PFDLED-ECO-SF:  
AS/NZS 2293.1:2018 CLASSIFICATION TABLE

| ALLOWABLE LUMINAIRE MOUNTING HEIGHT (M) | LUMINAIRE MAXIMUM SPACING FOR EACH PLANE (M) |          |      |
|---|--|----------|------|
|   | C0   | C90/C270 | C180 |
| 2.1                                     | 11.5   | 11.5     | 11.5 |
| 2.4                                     | 13.2   | 13.2     | 13.2 |
| 2.7                                     | 14.8   | 14.8     | 14.8 |
| 3                                       | 16.5   | 16.5     | 16.5 |
| 3.3                                     | 18.1   | 18.1     | 18.1 |
| 3.6                                     | 19.8   | 19.8     | 19.8 |
| 4                                       | 22   | 22       | 22   |
| 4.5                                     | 24.5   | 24.5     | 24.5 |
| 5                                       | 25.2   | 25.2     | 25.2 |
| 6                                       | 26.4   | 26.4     | 26.4 |
| 7                                       | 27.3   | 27.3     | 27.3 |

## APPLICATIONS

All commercial and interior applications, apartments, shopping centres, hospitality and hospitals.

## OPTIONAL ACCESSORIES

Surface mount kit and recessed vandal kit.

## SPECIFICATIONS

- Wattage: Maximum 3W
- Lumens: 339lm
- Voltage: 240V
- Ingress Protection: IP20 rated
- Operating Temperature: 0°C to 40°C
- Lifetime: 50,000hrs (L70/B50)
- Colour: White
- Material: Polycarbonate
- Emergency Test/Operation: Self test/DALI/non-maintained
- Battery Specification: LiFePO4 battery, 1 cell 3.2V 3200mAh
- Emergency Classification: C0/C180:D63 & C90/C270 : D63

| PRODUCT CODE  | DESCRIPTION                                       | WATTAGE (W) | DIMENSION (MM)       | MASS (KG) |
|---------------|---|-------------|----------------------|-----------|
| PFDLED-ECO    | Pathfinder ECO DALI Recessed Emergency Light      | 3 (max)     | Ø 140 x H 34         | 0.3       |
| PFDLED-ECO-SF | Pathfinder ECO DALI Surface Mount Emergency Light | 3 (max)     | L 214 x W 214 x H 60 | 0.36      |

## ACCESSORY CODE

|           |                                |
|-----------|--------------------------------|
| PFSKIT-L2 | Pathfinder 2 Surface Kit White |
| FFLEDVK   | Recessed Vandal Kit            |

# PATHFINDER 2 DALI LED EMERGENCY LIGHT



COMPLETE WITH LITHIUM IRON PHOSPHATE BATTERY

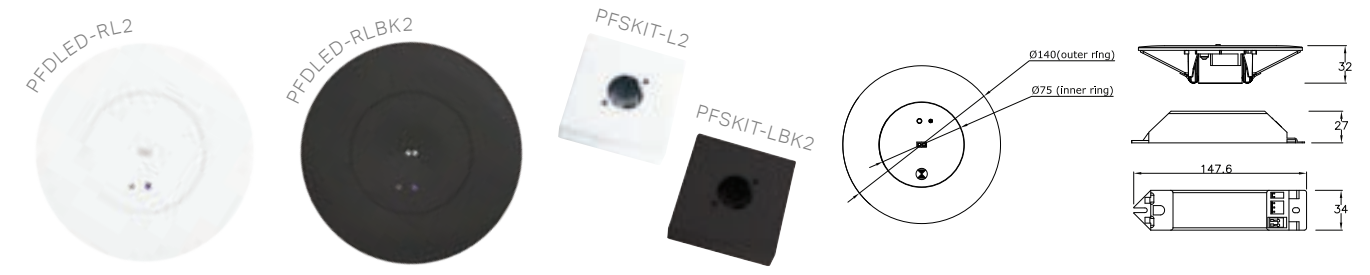

## FEATURES

- High luminous efficacy to maximise spacing
- Recessed mount with optional surface mount kit
- Available in white and black versions
- Flex and plug included for easy installation
- Self-test if not connected to DALI network with health status reported by bicolour LED indicator
- Standard version also available
- Complete with replaceable Lithium Iron Phosphate (LiFePO4) battery
- 4 year warranty including battery
- Compliant to AS/NZS 2293

## SPECIFICATIONS

- Wattage: Maximum 6W
- Lumens (emergency mode): 470lm
- Ingress Protection: IP20 rated
- Operating Temperature: 0°C to 40°C
- Lifetime: 50,000hrs (L70/B50)
- Materials: Polycarbonate
- Colour: White/Black
- Emergency Operation: Self test/DALI/non-maintained
- Emergency Classification: D80
- Battery Specification: LiFePO4 battery, 3 cell 9.6V 1500mAh

## OPTIONAL ACCESSORIES

Surface mount kit in black/white and recessed vandal kit.

## APPLICATIONS

All commercial and interior applications, apartments, shopping centres, hospitality, prisons and hospitals.

PFDLED-RL2, PFDLED-RLBK2:  
AS/NZS 2293.1:2018 CLASSIFICATION TABLE

| ALLOWABLE LUMINAIRE MOUNTING HEIGHT (M) | LUMINAIRE MAXIMUM SPACING FOR EACH PLANE (M) |          |      |
|---|--|----------|------|
|   | C0   | C90/C270 | C180 |
| 2.1                                     | 11.5   | 11.5     | 11.5 |
| 2.4                                     | 13.2   | 13.2     | 13.2 |
| 2.7                                     | 14.8   | 14.8     | 14.8 |
| 3                                       | 16.5   | 16.5     | 16.5 |
| 3.3                                     | 18.1   | 18.1     | 18.1 |
| 3.6                                     | 19.8   | 19.8     | 19.8 |
| 4                                       | 22   | 22       | 22   |
| 4.5                                     | 24.7   | 24.7     | 24.7 |
| 5                                       | 27.5   | 27.5     | 27.5 |
| 6                                       | 28.9   | 28.8     | 28.9 |
| 7                                       | 30   | 30       | 30   |
| 8                                       | 30.9   | 30.9     | 30.9 |
| 9                                       | 31.5   | 31.5     | 31.5 |
| 10                                      | 32.1   | 32.1     | 32.1 |
| 15                                      | 35.5   | 35.5     | 35.5 |
| 20                                      | 36.9   | 36.9     | 36.9 |

| PRODUCT CODE | DESCRIPTION                      | WATTAGE (W) | DIMENSION (MM)                          | MASS (KG) |
|--------------|----------------------------------|-------------|---|-----------|
| PFDLED-RL2   | Pathfinder 2 DALI Recessed White | 6 (max)     | Inner: Ø 75 x H 30 / Outer: Ø140 x H 30 | 0.3       |
| PFDLED-RLBK2 | Pathfinder 2 DALI Recessed Black | 6 (max)     | Inner: Ø 75 x H 30 / Outer: Ø140 x H 30 | 0.3       |

## ACCESSORY CODE

|                |                                      |
|----------------|--------------------------------------|
| BATPK1500/3L22 | LiFePO4 battery, 3 cell 9.6V 1500mAh |
| PFSKIT-L2      | Pathfinder 2 Surface Kit White       |
| PFSKIT-LBK2    | Pathfinder 2 Surface Kit Black       |
| FFLEDVK        | Recessed Vandal Kit                  |



# PATHFINDER 2 WEATHERPROOF EMERGENCY LIGHT



COMPLETE WITH LITHIUM IRON PHOSPHATE BATTERY

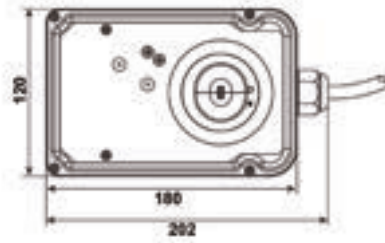
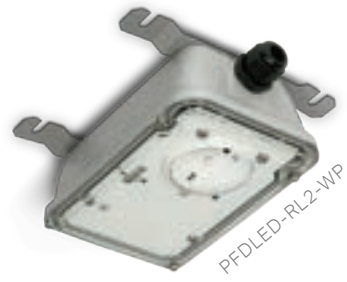

## FEATURES

- High luminous efficacy to maximise spacing
- Compact design with removable gear tray
- Robust powder coated die cast body and polycarbonate lens
- Self-test if not connected to DALI network with health status reported by bicolour LED indicator
- 1m 5 core flex and mounting brackets included
- Complete with Lithium Iron Phosphate (LiFePO4) battery
- 4 year warranty including battery
- Compliant to AS/NZS 2293

## APPLICATIONS

Ideal for providing omnidirectional coverage in applications such as train stations, car parks, correctional facilities, fire passages, mining and warehouses.

## SPECIFICATIONS

- Wattage: Maximum 5W
- Lumens: 466lm
- Voltage: 240V
- Ingress Protection: IP66 rated
- Impact Rating: IK10
- Operating Temperature: 0 °C to 50 °C
- Lifetime: 50,000hrs (L70/B10)
- Colour: White
- Material: Polycarbonate lens and aluminium die cast body
- Emergency Test/Operation: Self test/DALI/non-maintained
- Battery Specification: LiFePO4 battery, 3 cell 9.6V 1500mAh
- Emergency Classification: CO/C180: D100 & C90/C270: D63

### PFDLED-RL2-WP: AS/NZS 2293.1:2018 CLASSIFICATION TABLE

| ALLOWABLE LUMINAIRE MOUNTING HEIGHT (M) | LUMINAIRE MAXIMUM SPACING FOR EACH PLANE (M) |          |      |
|---|--|----------|------|
|   | C0   | C90/C270 | C180 |
| 2.1                                     | 11.5   | 11.5     | 11.5 |
| 2.4                                     | 13.2   | 13.2     | 13.2 |
| 2.7                                     | 14.8   | 14.8     | 14.8 |
| 3                                       | 16.5   | 16.5     | 16.5 |
| 3.3                                     | 18.1   | 18.1     | 18.1 |
| 3.6                                     | 19.8   | 19.8     | 19.8 |
| 4                                       | 22   | 22       | 22   |
| 4.5                                     | 24.7   | 24.5     | 24.5 |
| 5                                       | 27.5   | 25.2     | 25.2 |
| 6                                       | 31.3   | 26.4     | 26.4 |

| PRODUCT CODE  | DESCRIPTION   | WATTAGE (W) | DIMENSION (MM)         | MASS (KG) |
|---------------|---|-------------|------------------------|-----------|
| PFDLED-RL2-WP | Pathfinder IP66 IK10 Emergency Lighting Non-Maintained DALI | 5 (max)     | L 180 x W 120 x H 76.5 | 1.2       |

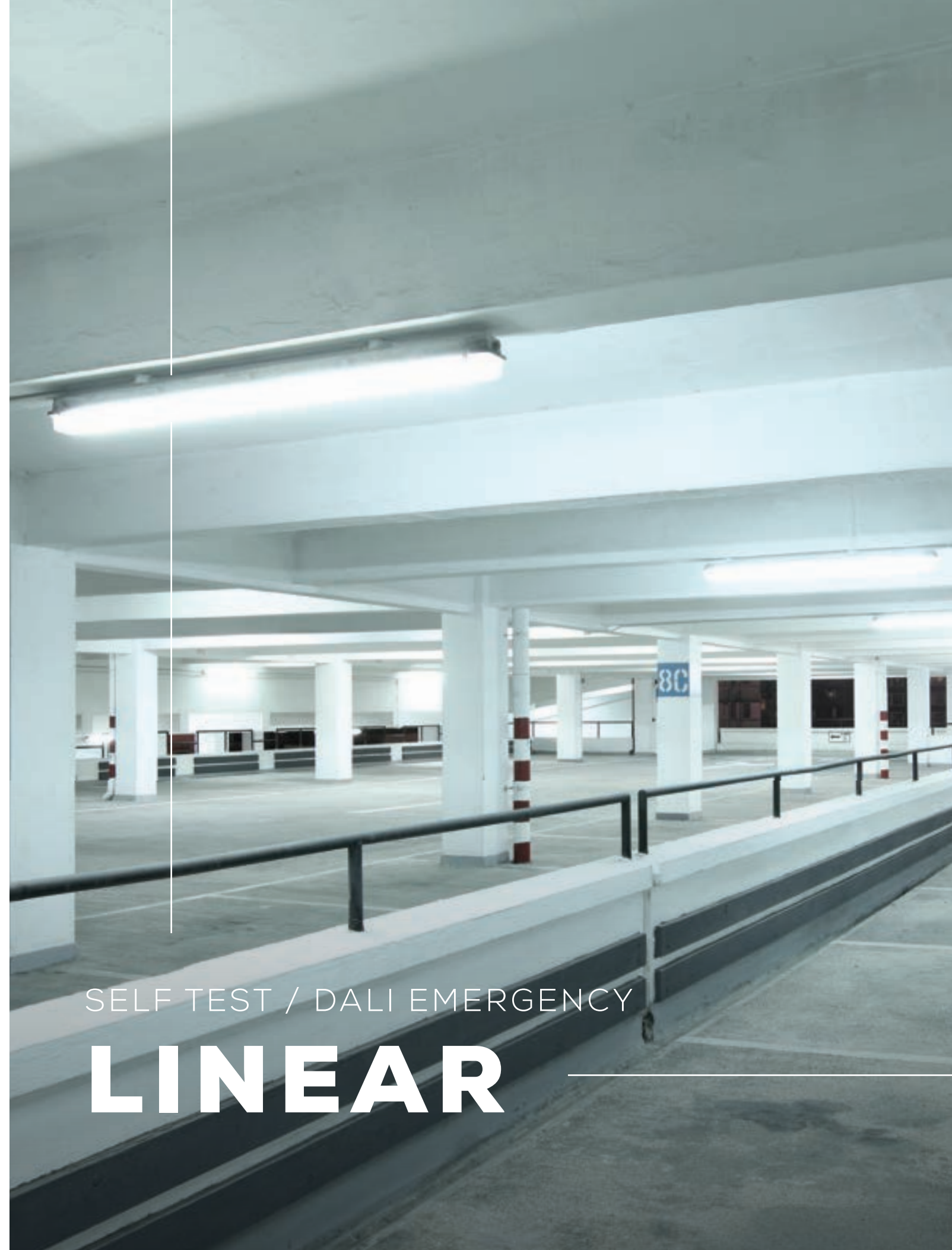

SELF TEST / DALI EMERGENCY

# LINEAR

# BWP PRO 2 LED EMERGENCY WEATHERPROOF BATTEN

COMPLETE WITH LITHIUM IRON PHOSPHATE BATTERY

LUMEN SELECT™

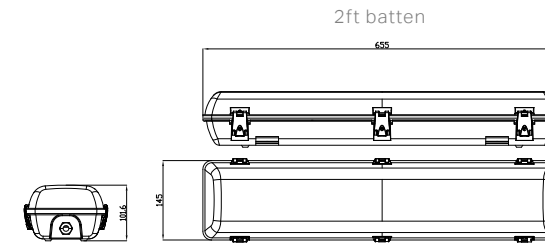
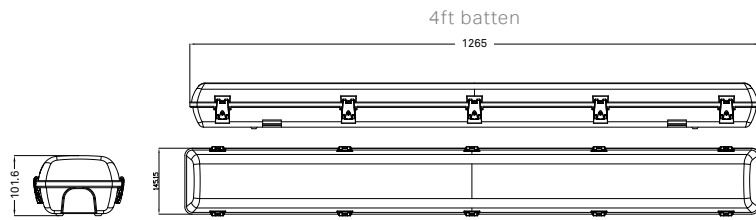

## FEATURES

- Available in two size, with the flexibility of three lumen outputs/wattages in one fitting
- Robust polycarbonate body with a durable foam seal and impact resistant opal polycarbonate lens
- Clip-in modular gear tray with safety lanyards for easy installation and maintenance
- Ceiling or wall mountable with stainless steel clips and mounting brackets included
- Self-test if not connected to DALI network with health status reported by bicolour LED indicator
- Available in sensor version with occupancy detection and daylight harvesting
- Complete with replaceable Lithium Iron Phosphate (LiFePO4) battery
- 7 year luminaire warranty and 4 year battery warranty
- Compliant to AS/NZS 2293

## APPLICATIONS

Suitable for factories, warehouses, washbays, outdoor security, lighting, car parks and light commercial spaces.

## SPECIFICATIONS

- Wattage (emergency mode): Maximum 5W
- Lumens (emergency mode): 586lm
- Voltage: 240V
- Ingress Protection: IP65 rated
- Impact Rating: IK08
- Operating Temperature: 0°C to 40°C
- Lifetime: 72,000hrs (L70/B50)
- Colour Temperature: 4000K
- Colour: Grey
- Material: Polycarbonate lens and body
- Dimming (AC mode): DALI, 1-10V, push dim
- Emergency Test/Operation: Self test/DALI/combined maintained
- Battery specification: LiFePO4 battery, 3 cell 9.6V 3200mAh
- Emergency Classification: C0/C180: D80 & C90/C270: D50

| PRODUCT CODE | DESCRIPTION   | WATTAGE (W) AC MODE | LUMENS (LM) AC MODE  | DIMENSION (MM)         | MASS (KG) |
|--------------|---|---------------------|----------------------|------------------------|-----------|
| BWP584D4/S4  | BWP PRO 2 Batten 1200mm DALI Emergency 58W/35W/25W          | 58<br>35<br>25      | 7169<br>4508<br>3278 | L 1265 x W 145 x H 102 | 2.8       |
| BWP352D4/S4  | BWP PRO 2 Batten 1200mm DALI Emergency 35W/25W/10W          | 35<br>25<br>10      | 4522<br>3117<br>1311 | L 655 x W 145 x H 102  | 1.6       |
| BWP584D4M/S4 | BWP PRO 2 Batten 1200mm DALI Emergency & Sensor 58W/35W/25W | 58<br>35<br>25      | 7169<br>4508<br>3278 | L 1265 x W 145 x H 102 | 2.8       |

BWP584D4/S4, BWP584D6/S4, BWP352D4/S4, BWP352D6/S4: AS/NZS 2293.1:2018 CLASSIFICATION TABLE

| ALLOWABLE LUMINAIRE MOUNTING HEIGHT (M) | LUMINAIRE MAXIMUM SPACING FOR EACH PLANE (M) |          |      |
|---|--|----------|------|
|   | C0   | C90/C270 | C180 |
| 2.1                                     | 11.5   | 11.5     | 11.5 |
| 2.4                                     | 13.2   | 13.2     | 13.2 |
| 2.7                                     | 14.8   | 14.8     | 14.8 |
| 3                                       | 16.5   | 16.5     | 16.5 |
| 3.3                                     | 18.1   | 18.1     | 18.1 |
| 3.6                                     | 19.8   | 19.8     | 19.8 |
| 4                                       | 22   | 21.8     | 22   |
| 4.5                                     | 24.7   | 22.5     | 24.7 |
| 5                                       | 27.5   | 23.1     | 27.5 |
| 6                                       | 28.9   | 25.2     | 28.9 |
| 7                                       | 30   | 27       | 30   |
| 8                                       | 30.9   | 28.53    | 30.9 |
| 9                                       | 31.5   | 29.9     | 31.5 |
| 10                                      | 32.1   | 31.2     | 32.1 |
| 15                                      | 38.3   | 35.5     | 38.3 |
| 20                                      | 41.2   | 36.9     | 41.1 |

SELF TEST / DALI EMERGENCY LINEAR



# SDW 2 LED EMERGENCY BATTEN

COMPLETE WITH LITHIUM IRON PHOSPHATE BATTERY

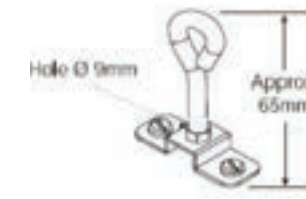

FOUR YEAR BATTERY WARRANTY

FIVE YEAR LUMINAIRE WARRANTY

## FEATURES

- Available in UV stabilised, high impact polycarbonate (SDWP) or acrylic (SDWA) diffusers
- Low glare, polycarbonate frosted diffuser with internal prism patterns for easy cleaning
- Tough fibre glass reinforced polyester body with lockable stainless steel clips
- Self-test if not connected to DALI network with health status reported by bicolour LED indicator
- Complete with Lithium Iron Phosphate (LiFePO4) battery
- 5 year luminaire warranty and 4 year battery warranty
- Compliant to AS/NZS 2293

## APPLICATIONS

Suitable for mines, chemical plants, abattoirs, food processing areas, dairies, agricultural plants, farm sheds and breweries.

## OPTIONAL ACCESSORIES

Eye suspension hook set and pipe clamp bracket.

## SPECIFICATIONS

- Wattage (emergency mode): 4W
- Lumens (emergency mode): 363lm
- Voltage: 240V
- Ingress Protection: IP66 rated
- Impact Rating: IK10
- Operating Temperature: 0°C to 40°C
- Lifetime: 72,000hrs (L70/B50)
- Colour Temperature: 4000K
- Colour: Grey
- Materials: Polyester (reinforced) body
- Electrical Rating: Class 2
- Emergency Test/Operation: Self test/DALI/maintained
- Battery Specification: LiFePO4 battery, 1 cell 3.2V 3200mAh
- Emergency Classification: C0/C180:D50 & C90/C270:D32

| PRODUCT CODE  | DESCRIPTION   | WATTAGE (W)<br>AC MODE | LUMENS (LM)<br>AC MODE | DIMENSION (MM)         | MASS (KG) |
|---------------|---|------------------------|------------------------|------------------------|-----------|
| SDWALS2D4M2   | SDW DALI 600L Acrylic Diffuser Integrated Driver        | 30<br>18               | 2800<br>1589           | L 662 x W 188 x H 115  | 2.3       |
| SDWALS4D4M2   | SDW DALI 1200L Acrylic Diffuser Integrated Driver       | 51<br>30               | 5614<br>2900           | L 1272 x W 188 x H 115 | 4.2       |
| SDWALS4D4M2RM | SDW DALI 1200L Acrylic Diffuser Remote Driver           | 51<br>30               | 5614<br>2900           | L 1272 x W 188 x H 115 | 4.2       |
| SDWPLS2D4M2   | SDW DALI 600L Polycarbonate Diffuser Integrated Driver  | 30<br>18               | 2800<br>1589           | L 662 x W 188 x H 115  | 2.3       |
| SDWPLS4D4M2   | SDW DALI 1200L Polycarbonate Diffuser Integrated Driver | 51<br>30               | 5614<br>2900           | L 1272 x W 188 x H 115 | 4.2       |

## ACCESSORY CODE

|           |  |
|-----------|--|
| 99018918  | Eye Suspension Hook Set                |
| PMB32/SDW | Pipe Clamp Mounting Bracket (Ø42-46mm) |

SDWALS4D4M2, SDWPLS4D4M2, SDWALS4D4M2RM: AS/NZS 2293.1:2018 CLASSIFICATION TABLE

| ALLOWABLE LUMINAIRE MOUNTING HEIGHT (M) | LUMINAIRE MAXIMUM SPACING FOR EACH PLANE (M) |          |      |
|---|--|----------|------|
|   | C0   | C90/C270 | C180 |
| 2.1                                     | 11.5   | 11.5     | 11.5 |
| 2.4                                     | 13.2   | 13.2     | 13.2 |
| 2.7                                     | 14.8   | 14.8     | 14.8 |
| 3                                       | 16.5   | 16.5     | 16.5 |
| 3.3                                     | 18.1   | 17.6     | 18.1 |
| 3.6                                     | 19.8   | 18       | 19.8 |
| 4                                       | 21.8   | 18.5     | 21.8 |
| 4.5                                     | 22.5   | 19.4     | 22.5 |
| 5                                       | 23.1   | 20.4     | 23.1 |
| 6                                       | 24.1   | 22.1     | 24.1 |
| 7                                       | 24.9   | 23.5     | 24.9 |
| 8                                       | 25.4   | 24.8     | 25.4 |

SDWALS2D4M2, SDWPLS2D4M2: AS/NZS 2293.1:2018 CLASSIFICATION TABLE

| ALLOWABLE LUMINAIRE MOUNTING HEIGHT (M) | LUMINAIRE MAXIMUM SPACING FOR EACH PLANE (M) |          |      |
|---|--|----------|------|
|   | C0   | C90/C270 | C180 |
| 2.1                                     | 11.5   | 11.5     | 11.5 |
| 2.4                                     | 13.2   | 13.2     | 13.2 |
| 2.7                                     | 14.8   | 14.8     | 14.8 |
| 3                                       | 16.5   | 16.5     | 16.5 |
| 3.3                                     | 18.1   | 17.6     | 18.1 |
| 3.6                                     | 19.8   | 18       | 19.8 |
| 4                                       | 21.8   | 18.5     | 21.8 |
| 4.5                                     | 22.5   | 19       | 22.5 |
| 5                                       | 23.1   | 19.5     | 23.1 |
| 6                                       | 24.1   | 20.7     | 24.1 |
| 7                                       | 24.9   | 22.6     | 24.9 |
| 8                                       | 25.4   | 24.1     | 25.4 |

# VANDALUX LED EMERGENCY WEATHERPROOF BATTEN

COMPLETE WITH LITHIUM IRON PHOSPHATE BATTERY

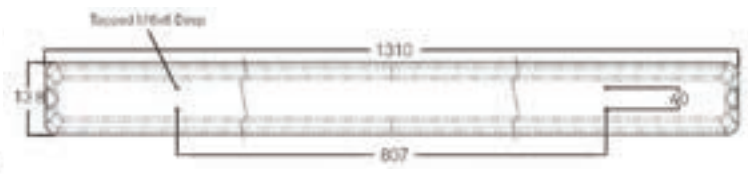

LUMEN SELECT™

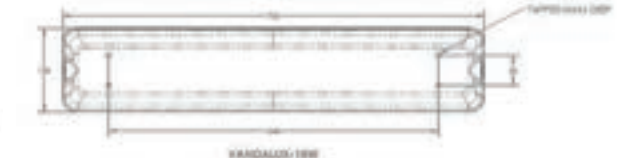
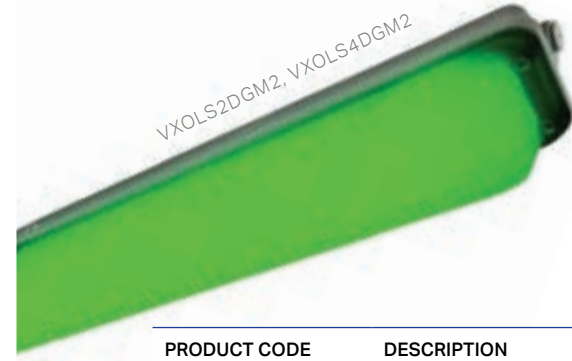

## FEATURES

- Vandal proof and anti-ligature, die-cast marine grade aluminum body with a powdercoated finish and frosted polycarbonate lens to resist impact
- Flexibility of multiple lumen outputs/wattages in one fitting
- Security screws, removable gear tray and single gasket included
- Available in wash bay version with green LED's, ideal for industrial eyewash stations
- Self-test if not connected to DALI network with health status reported by bicolour LED indicator
- Complete with Lithium Iron Phosphate (LiFePO4) battery
- 5 year luminaire warranty and 4 year battery warranty
- Compliant to AS/NZS 2293

## APPLICATIONS

Built tough for all levels of industry and public areas including transport facilities, schools, heavy industry and high vandalism areas. Green washbay version is ideal for eyewash stations.

## OPTIONAL ACCESSORIES

Flat wall mount bracket.

## SPECIFICATIONS

- Wattage (emergency mode): Maximum 3W
- Lumens (emergency mode):
  - Standard 700L @ 400lm
  - Standard 1300L @ 361lm
  - Washbays @ 350lm
- Voltage: 240V
- Ingress Protection: IP66 rated
- Impact Rating: IK10
- Operating Temperature: 0°C to 50°C
- Lifetime:
  - Standard 72,000hrs (L70/B10)
  - Washbay 60,000hrs (L70/B50)
- Colour Temperature:
  - Standard 4000K
  - Washbay 477K
- Colour: Grey
- Material: Polycarbonate lens and aluminium body
- Emergency Test/Operation: Self test/DALI/maintained
- Battery Specification: LiFePO4 battery, 1 Cell 3.2V 3200mAh
- Emergency Classification:
  - Standard 700L: C0/C180: D50 C90/C270: D32
  - Standard 1300L: C0/C180: D50 & C90/C270:D25

| PRODUCT CODE | DESCRIPTION                                       | WATTAGE (W)<br>AC MODE | LUMENS (LM)<br>AC MODE | DIMENSION (MM)         | MASS (KG) |
|--------------|---|------------------------|------------------------|------------------------|-----------|
| VXOLS2D4M2   | Vandalux LS 700L DALI Emergency                   | 33                     | 3861                   | L 700 x W 138 x H 114  | 4         |
|              |   | 28                     | 3351                   |                        |           |
|              |   | 20                     | 2510                   |                        |           |
|              |   | 16                     | 2114                   |                        |           |
| VXOLS2D4M2K  | Vandalux LS 700L DALI Emergency Retro Kit + Diff  | 33                     | 3861                   | L 700 x W 138 x H 114  | 4         |
|              |   | 28                     | 3351                   |                        |           |
|              |   | 20                     | 2510                   |                        |           |
|              |   | 16                     | 2114                   |                        |           |
| VXOLS4D4M2   | Vandalux LS 1300L DALI Emergency                  | 63                     | 7121                   | L 1310 x W 138 x H 114 | 8         |
|              |   | 53                     | 6153                   |                        |           |
|              |   | 37                     | 4576                   |                        |           |
|              |   | 30                     | 3837                   |                        |           |
| VXOLS4D4M2K  | Vandalux LS 1300L DALI Emergency Retro Kit + Diff | 63                     | 7121                   | L 1310 x W 138 x H 114 | 8         |
|              |   | 53                     | 6153                   |                        |           |
|              |   | 37                     | 4576                   |                        |           |
|              |   | 30                     | 3837                   |                        |           |
| VXOLS2DGM2   | Vandalux LS 700L DALI Green Emergency             | 36                     | 3861                   | L 700 x W 138 x H 114  | 4         |
|              |   | 32                     | 3596                   |                        |           |
|              |   | 23                     | 2510                   |                        |           |
|              |   | 20                     | 1840                   |                        |           |
| VXOLS4DGM2   | Vandalux LS 1300L DALI Green Emergency            | 65                     | 5628                   | L 1310 x W 138 x H 114 | 8         |
|              |   | 55                     | 5047                   |                        |           |
|              |   | 38                     | 4092                   |                        |           |
|              |   | 32                     | 3596                   |                        |           |
|              |   | 23                     | 2262                   |                        |           |

## ACCESSORY CODE

C33VANDALUX Flat wall mount bracket, mild steel, hot dip galvanised finish

VXOLS2D4M2: AS/NZS 2293.1:2018 CLASSIFICATION TABLE

| ALLOWABLE LUMINAIRE MOUNTING HEIGHT (M) | LUMINAIRE MAXIMUM SPACING FOR EACH PLANE (M) |          |      |
|---|--|----------|------|
|   | C0   | C90/C270 | C180 |
| 2.1                                     | 11.5   | 11.5     | 11.5 |
| 2.4                                     | 13.2   | 13.2     | 13.2 |
| 2.7                                     | 14.8   | 14.8     | 14.8 |
| 3                                       | 16.5   | 16.5     | 16.5 |
| 3.3                                     | 18.1   | 17.6     | 18.1 |
| 3.6                                     | 19.8   | 16.5     | 19.8 |
| 4                                       | 21.8   | 18       | 21.8 |
| 4.5                                     | 22.5   | 18.5     | 22.5 |
| 5                                       | 23.1   | 19.4     | 23.1 |
| 6                                       | 24.1   | 22.1     | 24.1 |
| 7                                       | 24.9   | 22.1     | 24.9 |
| 8                                       | 25.6   | 23.5     | 25.6 |

VXOLS4D4M2: AS/NZS 2293.1:2018 CLASSIFICATION TABLE

| ALLOWABLE LUMINAIRE MOUNTING HEIGHT (M) | LUMINAIRE MAXIMUM SPACING FOR EACH PLANE (M) |          |      |
|---|--|----------|------|
|   | C0   | C90/C270 | C180 |
| 2.1                                     | 11.5   | 11.5     | 11.5 |
| 2.4                                     | 13.2   | 13.2     | 13.2 |
| 2.7                                     | 14.8   | 14.8     | 14.8 |
| 3                                       | 16.5   | 15.7     | 16.5 |
| 3.3                                     | 18.1   | 16.1     | 18.1 |
| 3.6                                     | 19.8   | 16.5     | 19.8 |
| 4                                       | 21.8   | 17.3     | 21.8 |
| 4.5                                     | 22.5   | 18.3     | 22.5 |
| 5                                       | 23.1   | 19.1     | 23.1 |
| 6                                       | 24.1   | 20.7     | 24.1 |
| 7                                       | 24.9   | 22       | 24.9 |
| 8                                       | 25.4   | 23       | 25.4 |



# VANDAGUARD LED EMERGENCY WEATHERPROOF BATTEN

COMPLETE WITH LITHIUM IRON PHOSPHATE BATTERY



LUMEN SELECT™

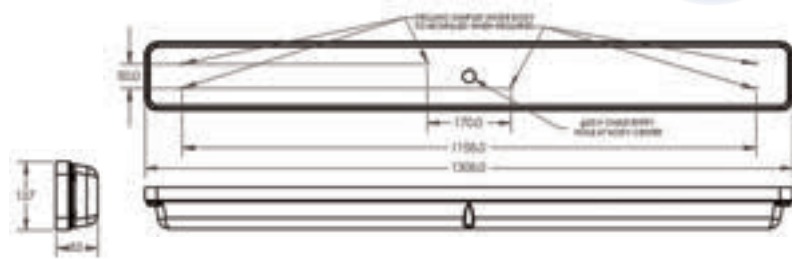

## FEATURES

- Vandal proof and anti-ligature, die-cast marine grade aluminum body with a powdercoated finish and frosted polycarbonate lens to resist impact
- Flexibility of five lumen outputs/wattages in one fitting
- Security screws, removable gear tray and single gasket included
- Self-test if not connected to DALI network with health status reported by bicolour LED indicator
- Complete with Lithium Iron Phosphate (LiFePO4) battery
- 5 year luminaire warranty and 4 year battery warranty
- Compliant to AS/NZS 2293

## APPLICATIONS

Tough for all levels of industry and public areas including transport facilities, schools, heavy industry and high vandalism areas.

## SPECIFICATIONS

- Wattage (emergency mode): Maximum 3W
- Lumens (emergency mode): 360lm
- Voltage: 240V
- Ingress Protection: IP66 rated
- Impact Rating: IK10
- Operating Temperature: 0°C to 40°C
- Lifetime: 60,000hrs (L70/B50)
- Colour Temperature: 4000K
- Colour: Grey
- Material: Polycarbonate lens and aluminium body
- Emergency Test/Operation: Self test/DALI/ maintained
- Battery Specification: LiFePO4 battery, 2 Cell 6.4V 3200mAh
- Emergency Classification: C0/C180: D50 C90/C270: D32

### VGOLS4D4M2: AS/NZS 2293.1:2018 CLASSIFICATION TABLE

| ALLOWABLE LUMINAIRE MOUNTING HEIGHT (M) | LUMINAIRE MAXIMUM SPACING FOR EACH PLANE (M) |          |      |
|---|--|----------|------|
|   | C0   | C90/C270 | C180 |
| 2.1                                     | 11.5   | 11.5     | 11.5 |
| 2.4                                     | 13.2   | 13.2     | 13.2 |
| 2.7                                     | 14.8   | 14.8     | 14.8 |
| 3                                       | 16.5   | 15.7     | 16.5 |
| 3.3                                     | 18.1   | 16.1     | 18.1 |
| 3.6                                     | 19.8   | 16.5     | 19.8 |
| 4                                       | 21.8   | 17.3     | 21.8 |
| 4.5                                     | 22.5   | 18.3     | 22.5 |
| 5                                       | 23.1   | 19.1     | 23.1 |
| 6                                       | 24.1   | 20.7     | 24.1 |
| 7                                       | 24.9   | 22       | 24.9 |
| 8                                       | 25.4   | 23       | 25.4 |

| PRODUCT CODE | DESCRIPTION   | WATTAGE (W) AC MODE | LUMENS (LM) AC MODE | DIMENSION (MM)        | MASS (KG) |
|--------------|---|---------------------|---------------------|-----------------------|-----------|
| VGOLS4D4M2   | Vandaguard Lumen Select 4FT DALI 4000K Maintained Emergency 2HR | 62                  | 7241                | L 1308 x W 137 x H 83 | 8         |
|              |   | 53                  | 6313                |                       |           |
|              |   | 38                  | 4800                |                       |           |
|              |   | 31                  | 3963                |                       |           |
|              |   | 23                  | 2959                |                       |           |

### ACCESSORY CODE

|                 |                                      |
|-----------------|--------------------------------------|
| DGLCEM3200/2L12 | LiFePO4 battery, 2 cell 6.4V 3200mAh |
|-----------------|--------------------------------------|

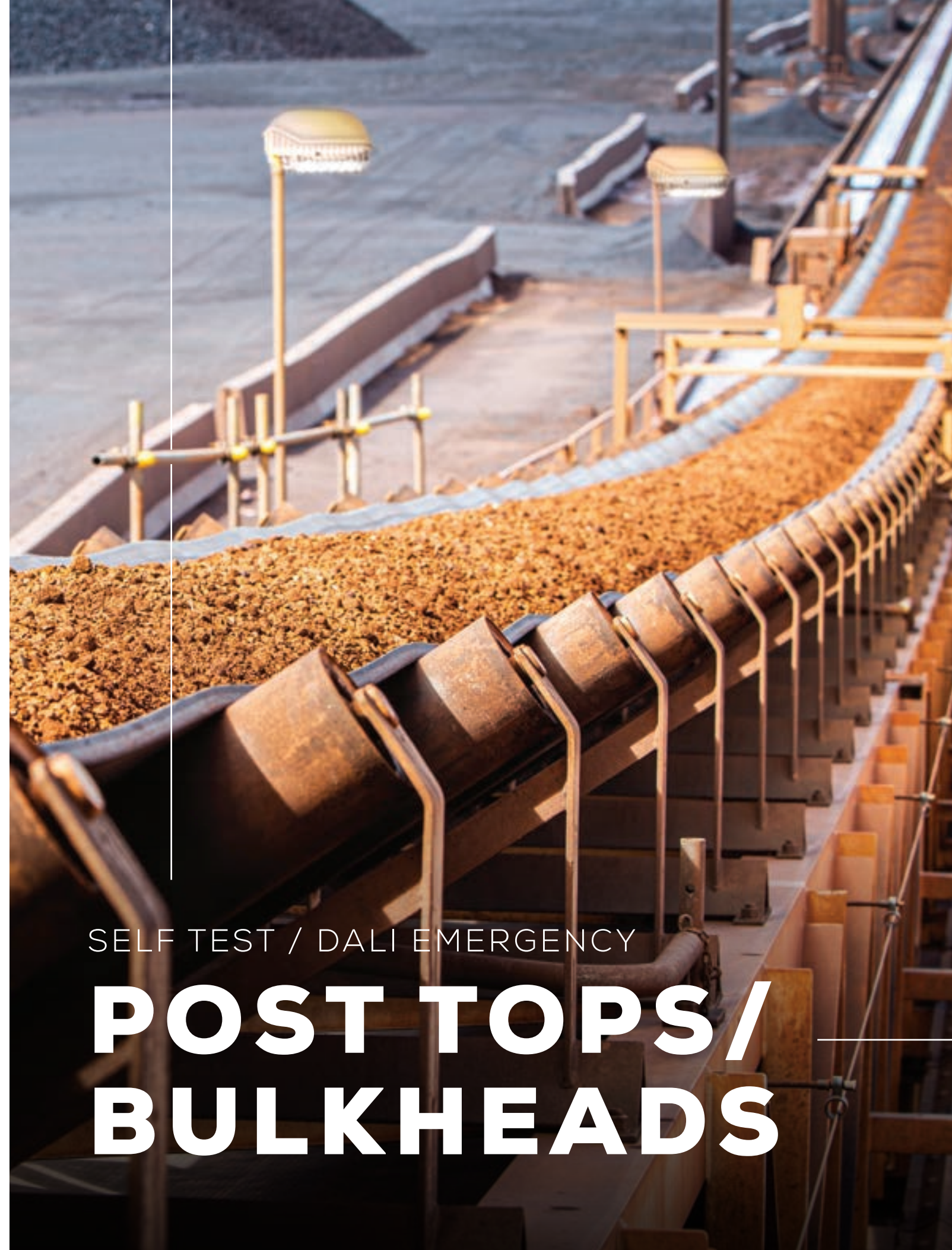

SELF TEST / DALI EMERGENCY

# POST TOPS / BULKHEADS



# MINE MASTER LED EMERGENCY POST TOP GEN2

COMPLETE WITH LITHIUM IRON PHOSPHATE BATTERY



MRA00L2N, MRA35L2M, MRS35L2M, MRA40EGM

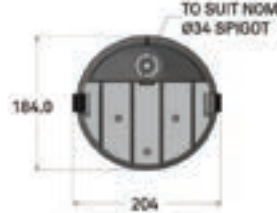
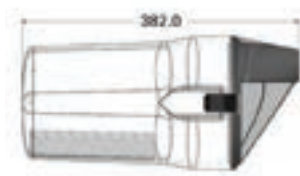

## FEATURES

- Robust and resistant to corrosion with IP66 aluminium or IP65 stainless steel housing available
- High performance optics with improved illumination uniformity for consistent site designs
- UV resistant moulded lens with integral IP66 silicone seal
- Suits standard diameter 34mm poles and spigot brackets
- Available in green LED version, ideal for industrial eye wash stations
- Self-test if not connected to DALI network with health status reported by bicolour LED indicator
- Complete with replaceable Lithium Iron Phosphate (LiFePO4) battery
- 5 year luminaire warranty and 4 year battery warranty
- Compliant to AS/NZS 2293

## APPLICATIONS

Designed for the mining industry and other arduous environments.

## SPECIFICATIONS

- Wattage (emergency mode): Maximum 3W
- Lumens (emergency mode): 372lm
- Voltage: 240V
- Ingress Protection: IP66 (aluminium) or IP65 (stainless steel)
- Impact Rating: IK10 body and IK06 optics
- Operating Temperature: 0 °C to 50 °C
- Lifetime: 54,000hrs (L70/B50)
- Colour Temperature: 4000K
- Colour: Grey
- Material: Acrylic lens, aluminium or stainless steel body
- Emergency Test/Operation: Self test/DALI with maintained or non-maintained options
- Battery Specification: LiFePO4 battery, 1 cell 3.2V 3200mAh
- Emergency Classification: C0:C40 C90:D80 C180:E32

MRA00L2N, MRA35L2M, MRS35L2M, MRA40EGM:  
AS/NZS 2293.1:2018 CLASSIFICATION TABLE

| ALLOWABLE LUMINAIRE MOUNTING HEIGHT (M) | LUMINAIRE MAXIMUM SPACING FOR EACH PLANE (M) |          |      |
|---|--|----------|------|
|   | C0   | C90/C270 | C180 |
| 2.1                                     | 11.5   | 21.1     | 9.4  |
| 2.4                                     | 11.5   | 22       | 10.2 |
| 2.7                                     | 12   | 22.8     | 11.2 |
| 3                                       | 12.6   | 23.6     | 12   |
| 3.3                                     | 13.1   | 24.3     | 12.8 |
| 3.6                                     | 13.6   | 25       | 13.4 |
| 4                                       | 14.4   | 25.8     | 14.4 |
| 4.5                                     | 15.4   | 26.7     | 15.4 |
| 5                                       | 16.2   | 27.5     | 16.2 |
| 6                                       | 17.8   | 28.9     | 17.8 |
| 7                                       | 19   | 30       | 19   |
| 8                                       | 19.8   | 30.9     | 19.8 |

| PRODUCT CODE | DESCRIPTION                              | WATTAGE (W) AC MODE | LUMENS (LM) AC MODE | DIMENSION (MM)        | MASS (KG) |
|--------------|--|---------------------|---------------------|-----------------------|-----------|
| MRA00L2N     | Mine Master 2 Aluminium Non-Maintained   | 35                  | 3600                | L 380 x W 204 x H 184 | 4.55      |
| MRA35L2M     | Mine Master 2 Aluminium Maintained       | 35                  | 3600                | L 380 x W 204 x H 184 | 5.12      |
| MRS35L2M     | Mine Master 2 Stainless Steel Maintained | 35                  | 3600                | L 380 x W 204 x H 184 | 4.23      |
| MRA40EGM     | Mine Master 2 Aluminium Maintained Green | 40                  | 2650                | L 380 x W 204 x H 184 | 5.12      |

## ACCESSORY CODE

|                 |  |
|-----------------|--|
| DGLCEM3200/1L11 | LiFePO4 battery, 1 cell 3.2V 3200mAh                           |
| MRALEDDIFFKIT   | Mine Master LED Diffuser Kit                                   |
| C33VANDALUX     | Flat wall mount bracket, mild steel, hot dip galvanised finish |

# ALIEN LED EMERGENCY POST TOP GEN2

COMPLETE WITH LITHIUM IRON PHOSPHATE BATTERY



ALN35D4MT3B4

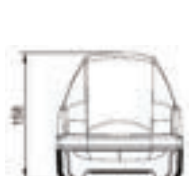
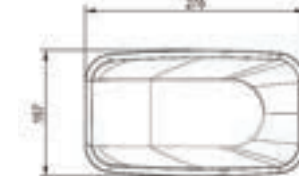

## FEATURES

- Built for harsh conditions and continuous vibration
- Robust die-cast marine grade aluminum body with a powdercoated finish
- Precision optics to maximise spacing and achieve uniform illumination
- Suits standard diameter 34mm poles and spigot brackets
- 4m heavy duty cable supplied as standard
- Self-test if not connected to DALI network with health status reported by bicolour LED indicator
- Complete with Lithium Iron Phosphate (LiFePO4) battery
- 5 year luminaire warranty and 4 year battery warranty
- Compliant to AS/NZS 2293

## APPLICATIONS

Ideal for conveyors, platforms and walkways.

## OPERATIONAL ACCESSORIES

Wire guard and flat wall mount bracket.

## SPECIFICATIONS

- Wattage (emergency mode): Maximum 3W
- Lumens (emergency mode): 251lm
- Voltage: 240V
- Ingress Protection: IP66 rated
- Impact Rating: IK10
- Operating Temperature: 0 °C to 50 °C
- Lifetime: 54,000hrs (L70/B50)
- Colour Temperature: 4000K
- Colour: Grey RAL9007
- Material: Aluminium
- Emergency Test/Operation: Self test/DALI/maintained
- Battery Specification: LiFePO4 battery, 1 cell 3.2V 3200mAh
- Emergency Classification: C0/C180: D10 & C90/C270:D9

ALN35D4MT3B4:  
AS/NZS 2293.1:2018 CLASSIFICATION TABLE

| ALLOWABLE LUMINAIRE MOUNTING HEIGHT (M) | LUMINAIRE MAXIMUM SPACING FOR EACH PLANE (M) |          |      |
|---|--|----------|------|
|   | C0   | C90/C270 | C180 |
| 2.1                                     | 11.5   | 11.3     | 11.5 |
| 2.4                                     | 13.2   | 12       | 13.2 |
| 2.7                                     | 14.8   | 12       | 14.8 |
| 3                                       | 16.5   | 13.4     | 16.5 |
| 3.3                                     | 18.1   | 14       | 18.1 |
| 3.6                                     | 19.8   | 14.5     | 19.8 |
| 4                                       | 22   | 15.2     | 22   |
| 4.5                                     | 24.5   | 16       | 24.5 |
| 5                                       | 25.2   | 16.9     | 25.2 |
| 6                                       | 26.4   | 18.7     | 26.4 |
| 7                                       | 27.3   | 20.1     | 27.3 |
| 8                                       | 28   | 21.2     | 28   |

| PRODUCT CODE | DESCRIPTION                                | WATTAGE (W) AC MODE | LUMENS (LM) AC MODE | DIMENSION (MM)        | MASS (KG) |
|--------------|--|---------------------|---------------------|-----------------------|-----------|
| ALN35D4MT3B4 | Alien DALI Maintained Emergency T3B Optics | 35                  | 3975                | L 277 x W 157 x H 158 | 3.5       |

## ACCESSORY CODE

|             |  |
|-------------|--|
| ALN/WG      | Wire Guard 316 Stainless Steel                                 |
| C33VANDALUX | Flat wall mount Bracket, mild steel, hot dip galvanised finish |



# NEXUS LED EMERGENCY BULKHEAD GEN2

COMPLETE WITH LITHIUM IRON PHOSPHATE BATTERY

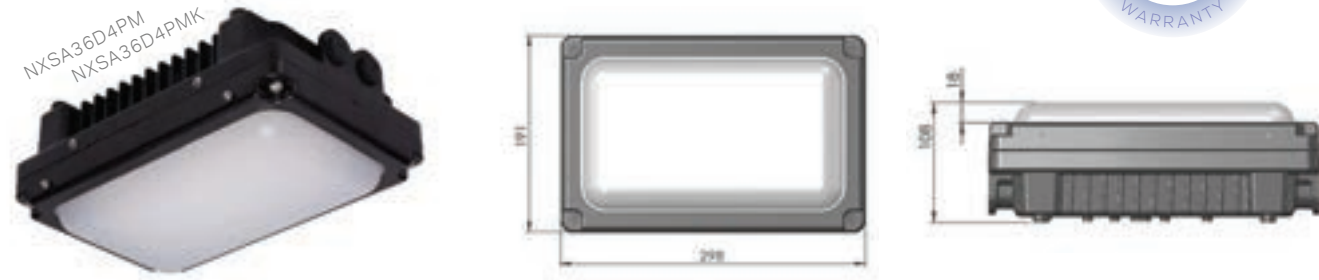

## FEATURES

- Robust and corrosion resistant marine grade aluminum body, with polycarbonate lens
- Acrylic diffuser and retrofit kits available to replace older HID, HPS and CFL control gears
- Self-test if not connected to DALI network with health status reported by bicolour LED indicator
- Complete with Lithium Iron Phosphate (LiFePO4) battery
- 5 year luminaire warranty and 4 year battery warranty
- Compliant to AS/NZS 2293

## APPLICATIONS

Built for the harsh Australian conditions and adverse lighting applications.

## OPTIONAL ACCESSORIES

Polycarbonate and acrylic replacement diffusers.

## SPECIFICATIONS

- Wattage (emergency mode): Maximum 3W
- Lumens (emergency mode): 250lm
- Voltage: 240V
- Ingress Protection: IP66 rated
- Impact Rating: IK10
- Operating Temperature: 0°C to 50°C
- Lifetime: 72,000hrs (L70/B10)
- Colour Temperature: 4000K
- Colour: Black
- Material: LM6 grade Aluminium
- Emergency Test/Operation: Self test/DALI/maintained
- Battery Specification: LiFePO4 battery, 1 cell 3.2V 3200mAh
- Emergency Classification: NXSA36D4PM: C0/C180: D32 & C90/C270:D40

NXSA36D4PM:  
AS/NZS 2293.1:2018 CLASSIFICATION TABLE

| ALLOWABLE LUMINAIRE MOUNTING HEIGHT (M) | LUMINAIRE MAXIMUM SPACING FOR EACH PLANE (M) |          |      |
|---|--|----------|------|
|   | C0   | C90/C270 | C180 |
| 2.1                                     | 11.5   | 11.5     | 11.5 |
| 2.4                                     | 13.2   | 13.2     | 13.2 |
| 2.7                                     | 14.8   | 14.8     | 14.8 |
| 3                                       | 16.5   | 16.5     | 16.5 |
| 3.3                                     | 17.6   | 18.1     | 17.6 |
| 3.6                                     | 18   | 19.5     | 18   |
| 4                                       | 18.5   | 20.1     | 18.5 |
| 4.5                                     | 19   | 20.7     | 17.6 |
| 5                                       | 19.5   | 21.2     | 19.5 |
| 6                                       | 20.1   | 22.1     | 20.1 |
| 7                                       | 20.7   | 22.6     | 20.7 |
| 8                                       | 20.6   | 23       | 20.6 |

| PRODUCT CODE | DESCRIPTION   | WATTAGE (W) AC MODE | LUMENS (LM) AC MODE | DIMENSION (MM)        | MASS (KG) |
|--------------|---|---------------------|---------------------|-----------------------|-----------|
| NXSA36D4PM   | Nexus Aluminium 36W DALI Polycarbonate Maintained Emergency           | 36                  | 3372                | L 298 x W 191 x H 108 | 4         |
| NXSA36D4PMK  | Nexus Aluminium 36W DALI Polycarbonate Maintained Emergency Retro Kit | 36                  | 3372                | L 298 x W 191 x H 108 | 4         |

## ACCESSORY CODE

|            |  |
|------------|--|
| NXSPCDIFF  | Nexus Gen2 Polycarbonate Diffuser IK10 |
| NXSPMADIFF | Nexus Gen2 Acrylic Diffuser IK07       |

# EMERGENCY TECHNICAL STANDARDS AND GUIDELINES

## EMERGENCY LIGHTING

Emergency luminaires have captured the essence of design presence and continuity, satisfying the designer's needs and the installer's installation criteria. Meeting with compliance to AS60598-2-22 enables the design of emergency lighting units to be more flexible.

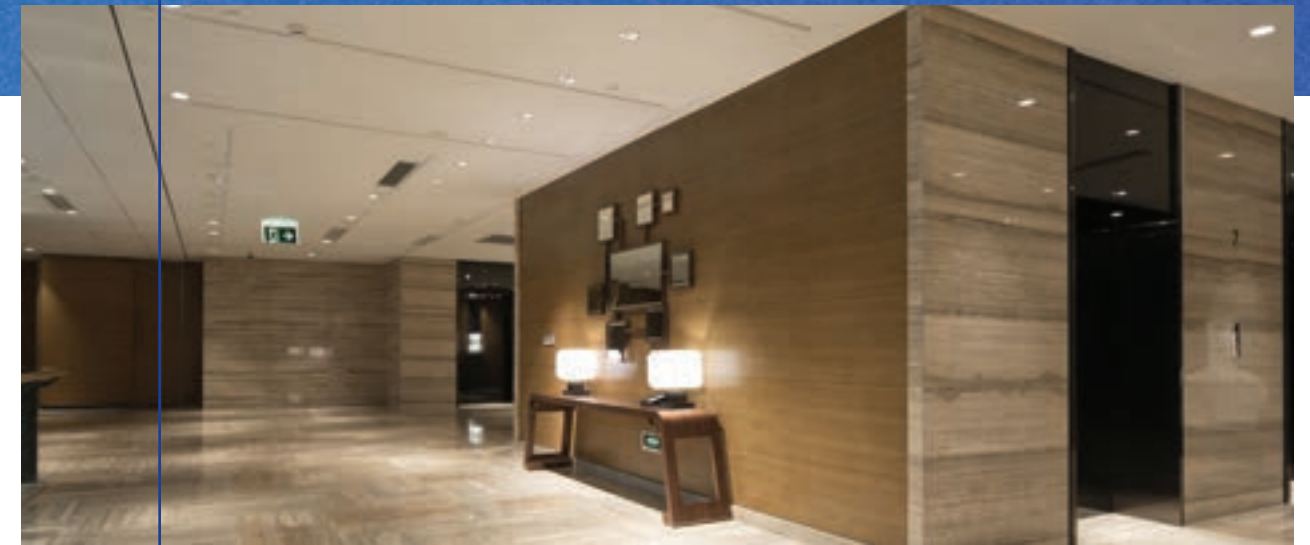

## EMC

Electromagnetic Compatibility (EMC) under the AS/NZS CISPR15:2011 deals with devices such as lighting/emergency lighting products that may have the potential to cause interference to radio communication systems. This may be mains disturbance (noise down the line), radiation (giving out interfering frequencies from components) or deceptively (interference of frequency due to external noise).

All Pierlite Emergency lighting/emergency lighting products comply with the above standard.

## EMERGENCY EVACUATION LIGHTING FOR BUILDINGS - AS/NZS 2293.1:2018

### Spacing of emergency luminaires in Australia

Spacing of emergency luminaires are based on illuminance calculations where the light reaches the floor directly from the emergency light source.

Minimum illuminance level for emergency lighting is 0.2 lux. Please use classification tables provided with each product. ie: FFRLED2

## EMERGENCY CLASSIFICATION

C0 - D32      C90/C270 - D32      C180 - D32

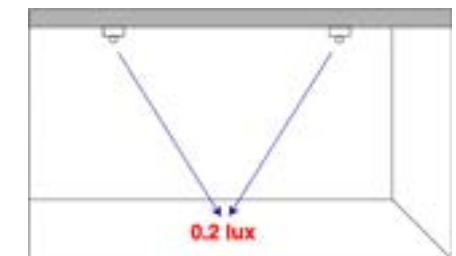

LC(AUST) - Classification of emergency luminaire to Australian standard. ie: FFRLED2

Emergency Classification

C0 - D32      C90/C270 - D33      C180 - D32



# SOLUTION FOCUSED WITH PROVEN RESULTS

## STANDARD REQUIREMENTS

The Emergency Lighting Working Group, a working group of Lighting Council Australia, provides the following advice regarding the 2018 and 2019 changes to emergency lighting standards in Australia.

The following emergency lighting standards are currently published:

**AS/NZS 2293.1:2018** Emergency lighting and exit signs for buildings. System design, installation and operation. *The major change includes significant updates in spacing table.*

**AS/NZS2293.3:2018** Emergency lighting and exit signs for buildings. Emergency luminaires and exit signs. *These standards replaced: AS/NZS2293.1:2005 and AS/NZS2293.3:2005.*

**AS/NZS2293.2:1995 and AS/NZS 2293.2:2019** Emergency escape lighting and exit signs for buildings. *Inspection and maintenance remains unchanged.*

AS/NZS2293.1:2005 and 1998 had already included significant changes, the following changes from the 1998 and 2015 versions still apply:

- Replacement of word 'exit' with pictogram
- Inclusion of detailed restrictions on use of arrows
- Revision of maximum viewing distances for exit signs
- Adoption of terminology from IEC60598.2.22
- Unlike the 1998 version, this standard is not a joint Australian/New Zealand document; there is no content specific to New Zealand

The principal reason for the AS/NZS2293.3:2005 edition of the standard is to specify requirements for exit signs employing internationally accepted pictograms, instead of the previously used word 'Exit'.

Terminology used to describe the subject matter has been modified in both standards to be compatible with that used in IEC60598.2.22 Luminaires Part 2.22

Particular requirements – luminaires for emergency lighting. The new terminology recognises that the term 'emergency lighting' includes four categories of lighting, each incorporating an alternative energy supply, as follows:

- Emergency escape lighting
- Illuminated emergency exit signs
- High risk task area lighting
- Standby lighting

However as reflected in the new series title, only two of these four categories are addressed in the AS/NZS 2293.1:2018 standards –namely emergency escape lighting and illuminated emergency exit signs.

## PICTOGRAMS

Typical pictorial elements as per AS/NZS2293.3:2018



Straight on from here    Left from here    Right from here

## SIZE OF PICTORIAL ELEMENTS

Minimum pictorial element height for all illuminated exit signage is 100mm.

There is no limit on the maximum pictorial element height. The four recommended pictorial element heights of 100, 150, 200 and 250mm correspond to maximum viewing distances as follows.

| Element Height (mm) | Maximum Viewing Distance (m) |
|---------------------|------------------------------|
| → 100 <150          | 16                           |
| → 150 <200          | 24                           |
| → 200 <250          | 32                           |
| → 250 ---           | 40                           |

The maximum viewing distance must be marked on the face of each diffuser located on the background, either within one of the elements or on additional background.

The Australian Building Codes Board recognised the new emergency lighting standards as at 1st May 2019. The new standards may be utilised on a project by project basis, if approved for the project by the applicable local authority.

## MODES OF OPERATION

Terminology used to describe the modes of operation has been modified to include luminaires with multiple emergency lamp configurations. Refer to the table below.

| EMERGENCY LUMINAIRE TYPE           | NORMAL OPERATION (I.E. MAINS OPERATING) | EMERGENCY OPERATION (I.E. MAINS FAILED) |
|------------------------------------|---|---|
| Non-maintained                     | OR                                      | OR                                      |
| Maintained                         | OR                                      | OR                                      |
| Combined maintained (IE Sustained) |   |   |
| Combined maintained                |   |   |

Legend: Non-energised lamp (lamp off) Energised lamp (lamp on)



Commercial Bay, Auckland - NZ



Wynyard Station, Sydney - NSW



Constitution Place, Canberra - ACT



Department of Primary Industries, Orange - NSW



251 St Georges Terrace, Perth - WA



## **NEW SOUTH WALES**

### **NATIONAL HEAD OFFICE**

Phone: 1300 799 300 | Fax: 1300 789 300  
96-112 Gow Street, Padstow NSW 2211  
Postal Address: PO BOX 314 Padstow NSW 2211

## **QUEENSLAND**

Phone: 1300 799 300 | Fax: 1300 789 300  
54 Berwick Street, Fortitude Valley QLD 4006  
Postal Address: PO Box 500 Fortitude Valley QLD 4006

## **VICTORIA / TASMANIA**

Phone: 1300 799 300 | Fax: 1300 789 300  
Unit 2, 20 Sabre Drive, Port Melbourne Vic 3207

## **SOUTH AUSTRALIA / NORTHERN TERRITORY**

Phone: 1300 799 300 | Fax: 1300 789 300  
Level 2, 191 Fullarton Rd, Dulwich SA 5065

## **WESTERN AUSTRALIA**

Phone: 1300 799 300 | Fax: 1300 789 300  
77 Truganina Road, Malaga WA 6090  
Postal Address: PO Box 2046 Malaga, WA 6944



**1300 799 300 | PIERLITE.COM.AU**



April 2022

Pierlite is a registered trademark of Signify Innovations Australia Pty Ltd ©Copyright Pierlite 2022. Signify Innovations Australia Pty Ltd and all directly related legal entities reserve the right to alter the specifications, designs or other features of any items herein and to discontinue any items at any time without notice and without liability.